

X72 Rubidium Oscillator

Designer's Reference and User Guide
Revision A – November 2004
Part Number 097-10603-01

Symmetricom, Inc.
2300 Orchard Parkway
San Jose, CA 95131-1017
U.S.A.

<http://www.symmetricom.com>

Copyright © 1999 – 2004 Symmetricom, Inc.
All rights reserved. Printed in U.S.A.

All product names, service marks, trademarks, and registered trademarks
used in this document are the property of their respective owners.

Contents

Purpose of This Guide	12
Who Should Read This Guide.	12
Structure of This Guide	12
Conventions Used in This Guide.	13
Warnings, Cautions, Recommendations, and Notes	14
Related Documents and Information.	15
Where to Find Answers to Product and Document Questions	15
What's New In This Guide.	15

Chapter 1 Description

Overview	18
Typical Applications	19
Specifications	21

Chapter 2 Design Integration Considerations

Mechanical Considerations	28
Mounting Recommendations	28
Recommended Mating Connectors	28
Integrating the X72 into a System.	29
Thermal Considerations	34
Thermal Tape	34
Water Condensation and Excessive Humidity	35
Excessive Dust	35
External Interfaces and Grounding	35
Electrical Interface.	36
X72 RF Outputs	36
X72 1 PPS Input and Output	36
Lock Signal	36
Service Signal.	37
X72 Frequency Control Signal	37
X72 ACMOS Output Frequency	37
Frequency Control Analog	38
Greater Than $\pm 1 \times 10^{-9}$ Internal or External Control	38
Time Response of External Frequency Control	38
Temperature Compensation of Frequency	38
Modifiable Unit Settings	39

X72 Susceptibility to Input Noise	40
Input Filtering	40
X72 Reliability and Maintenance	41
Reliability	41
Maintenance	41

Chapter 3 Installation and Operation

Installation	44
Site Selection	44
Turn-on Procedure	44
Start-up Sequence	45
Theory of Operation	47
Troubleshooting	48
Repairs	48
X72 Warranty	49

Appendix A X72 J1 Connector and Plug

Molex Connector	52
Molex Connector Plug Assembly	53
Edge Board Pinout	54
3.25 Inch Interface Cable	55
Edge Board Layout Drawing	56

Appendix B Symmetricom Serial Interface Protocol

Using the Symmetricom Serial Interface Protocol	58
Host Terminal Emulator Setup	58
Data Format	58
Factory Mode	61
Floating Point Number Representation	61

Appendix C Using the X72 Developer's Kit

Introduction	68
Mounting the X72 Unit	68
Interface Cabling/Circuit Cards	68
Symmetricom Serial Interface Protocol (SSIP)	69
Turn-on Procedure	69
Start-up Sequence	72

X72 Development Kit Hardware	73
Test Adapter Board and Edge Adapter Cards	73

Appendix D One Pulse Per Second Source Connection

Connection Requirements.	78
Background	78
X72 1PPS Functions	79
System Requirements.	80
X72 1PPS Algorithm Operation.	81
Factory Default	81
Setting the X72 for 1PPS Synchronization.	81
Changing the “y” Coefficients.	82
The “y” Coefficients – Factory Default	82
The “j” Command	83
The “g” Command	83
Flywheeling Recovery – Normal	85
Recovery with JamSynch.	86
X72 1PPS Algorithm Theory of Operation	87
X72 1PPS Algorithm High Level Flow Chart.	88
Initialization	89
Holdover	90
Calcslope	91
JamSynch.	92
Discipline.	93

Figures

1-1	X72 Rubidium Oscillator	18
1-2	Size Difference of X72 (top) and Vintage FRK Rb Oscillator	18
1-3	X72 Rubidium oscillator simplified block diagram	20
1-4	X72 Dimensions and Connector Pin Assignments	21
1-5	Total X72 Quiescent Power Dissipation, Typical (free convection)	25
1-6	Representative X.72 f/f versus Temperature (uncompensated).	25
2-1	Adapter Cards, Cables, and Options	28
2-2	Unpopulated Edge Board.	29
2-3	Standard Edge Board.	30
2-4	Standard Edge Board Mounting Example	30
2-5	Anchored Edge Board	31
2-6	Anchored Edge Board Mounting Example.	32
2-7	3.25-Inch Connector and Header.	32
2-8	3.25-Inch Connector Mounting Example	33
2-9	Standard Edge Board and LPRO Connector	34
3-1	Suggested Connections for X72, Initial Turn-on.	44
3-2	Sequence of Start-up Events	46
3-3	X72 Rb Control Loop Block Diagram.	47
A-1	Molex Connector	52
A-2	Molex Connector Plug Assembly	53
A-3	Edge Board Pinout Comparison	54
A-4	3.25 Inch Interface Cable Connections	55
A-5	Layout Drawing for Edge Board.	56
C-1	Suggested X72 Test Setup.	69
C-2	Top View of X72 Case	70
C-3	X72 Dimensions.	71
C-4	Top View of X72 Test Interface Board	73
C-5	Developer's Kit (P/N 106495-001) Interconnect Diagram	74
C-6	X72 Interface Options	75
D-1	X72 Time and Frequency Control System	79
D-2	Test Bench setup	80
D-3	Flywheeling Recover with 1PPS offset < 1 μ sec	85
D-4	Flywheeling Recover with 1PPS offset > 1 μ sec	86
D-5	X72 1PPS Algorithm States	88
D-6	X72 Initialize State	89
D-7	X72 Holdover State	90

D-8	X72 Calcslope State.....	91
D-9	X72 JamSynch State.....	92
D-10	X72 Discipline State.....	93

Tables

1-1	X72 Design Absolute Maximum Ratings	22
1-2	X72 Design Absolute Maximum Ratings	23
1-3	X72 Design Operating Characteristics	24
2-1	Hardware Selectable Items	39
2-2	Software Selectable Items	39
B-1	Floating Point Number Representation for SSIP	61
B-2	Run Mode Commands	62
B-3	Factory Mode Commands	63
B-4	Administrative Mode Commands	64
B-5	Output Control Status Register Structure	64
C-1	Connector J1 Signal Information	71
D-1	1PPS States Returned with the j Command	83
D-2	1PPS Firmware Versions	84

How to Use This Guide

This section describes the format, layout, and purpose of this guide.

In This Preface

- [Purpose of This Guide](#)
- [Who Should Read This Guide](#)
- [Structure of This Guide](#)
- [Conventions Used in This Guide](#)
- [Warnings, Cautions, Recommendations, and Notes](#)
- [Related Documents and Information](#)
- [Where to Find Answers to Product and Document Questions](#)
- [What's New In This Guide](#)

Purpose of This Guide

The *X72 Designer's Reference and User's Guide* provides basic recommendations for designing products to use Symmetricom's X72 Rubidium Oscillator. The guidelines in this user guide are generic because specific product requirements vary from application to application.

This material consists of a brief description of X72 design supported by block diagrams, description of environmental issues, installation guidelines, required mating connectors, and unit operation.

Who Should Read This Guide

This document is intended for engineers and telecommunications professionals who are designing, installing, operating or maintaining time, frequency, and synchronization systems having a requirement for a low profile and highly precise frequency generator.

To use this document effectively, you should have a good understanding of digital telecommunications technologies and analog frequency generation and synthesis techniques.

Structure of This Guide

This guide contains the following sections:

Chapter, Title	Description
Chapter 1, Description	This section contains a description of the X72 and lists its typical applications. It provides information on dimensions, performance, and connector pinouts.
Chapter 2, Design Integration Considerations	This section contains mechanical issues pertaining to X72 mounting and mating recommendations, including thermal and EMI considerations, external interfaces and grounding, frequency control, susceptibility to noise, and reliability goal.
Chapter 3, Installation and Operation	This section contains the information necessary to properly install and operate the X72 unit including a simplified theory of operation, and maintenance and warranty.
Appendix A, X72 J1 Connector and Plug	This appendix identifies the Molex J1 connector and its mating plug, and provides pinout information for the X72 edge board, and 3.25 inch (8.255 cm) cable.

Chapter, Title	Description
Appendix B, Symmetricom Serial Interface Protocol	This appendix describes use of the external communications link software.
Appendix C, Using the X72 Developer's Kit	This appendix describes the X72 developer's kit hardware.
Index	Provides references to individual topics within this guide.

Conventions Used in This Guide

This guide uses the following conventions:

- **Acronyms and Abbreviations** – Terms are spelled out the first time they appear in text. Thereafter, only the acronym or abbreviation is used.
- **Revision Control** – The title page lists the printing date and versions of the product this guide describes.
- **Typographical Conventions** – This guide uses the typographical conventions described in the table below.

When text appears this way...	... it means:
<i>X72 Rubidium Oscillator User's Guide</i>	The title of a document.
LOCK	An operating mode, alarm state, status, or chassis label.
Press Enter	A named keyboard key. The key name is shown as it appears on the keyboard. An explanation of the key's acronym or function immediately follows the first reference to the key, if required.
FC mode enabled	Text in a source file or a system prompt or other text that appears on a screen.
r>w r>a	A command you enter at a system prompt or text you enter in response to a program prompt. You must enter commands for case-sensitive operating systems exactly as shown.
<i>Lock-in</i>	A word or term being emphasized.
Symmetricom does not recommend...	A word or term given special emphasis.

Warnings, Cautions, Recommendations, and Notes

Warnings, Cautions, Recommendations, and Notes attract attention to essential or critical information in this guide. The types of information included in each are explained in the following examples.



Warning: To avoid serious personal injury or death, *do not* disregard warnings. All warnings use this symbol. Warnings are installation, operation, or maintenance procedures, practices, or statements, that if not strictly observed, may result in serious personal injury or even death.



Caution: To avoid personal injury, *do not* disregard cautions. All cautions use this symbol. Cautions are installation, operation, or maintenance procedures, practices, conditions, or statements, that if not strictly observed, may result in damage to, or destruction of, the equipment. Cautions are also used to indicate a long-term health hazard.



ESD Caution: To avoid personal injury and electrostatic discharge (ESD) damage to equipment, *do not* disregard ESD cautions. All ESD cautions use this symbol. ESD cautions are installation, operation, or maintenance procedures, practices, conditions, or statements that if not strictly observed, may result in possible personal injury, electrostatic discharge damage to, or destruction of, static-sensitive components of the equipment.



Electrical Shock Caution: To avoid electrical shock and possible personal injury, *do not* disregard electrical shock cautions. All electrical shock cautions use this symbol. Electrical shock cautions are practices, procedures, or statements, that if not strictly observed, may result in possible personal injury, electrical shock damage to, or destruction of components of the equipment.



Recommendation: All recommendations use this symbol. Recommendations indicate manufacturer-tested methods or known functionality. Recommendations contain installation, operation, or maintenance procedures, practices, conditions, or statements, that provide important information for optimum performance results.



Note: All notes use this symbol. Notes contain installation, operation, or maintenance procedures, practices, conditions, or statements, that alert you to important information, which may make your task easier or increase your understanding.

Related Documents and Information

See your Symmetricom representative or sales office for a complete list of available documentation.



Note: Symmetricom offers training courses designed to enhance your knowledge of the X72 Rubidium Oscillator. Contact your local representative or sales office for a complete list of courses and outlines.

Where to Find Answers to Product and Document Questions

For additional information about the products described in this guide, please contact your Symmetricom representative or your local sales office. You can also contact us on the web at www.symmetricom.com.

What's New In This Guide

This revision of this guide has a new format and typography to make the text easier to read. The following changes were also incorporated:

- Removed 5 volt option information throughout manual
- Updated FACMOS OUT signal function information in [Table 1-1](#) and [Table C-1](#)
- Updated P_{SO} information in [Table 1-3](#)
- Added the “t” command (Save Tuning Data) to [Table B-2](#)
- Updated SSIP control register information
- Updated the description for the “f” command (Adjust Frequency) to [Table B-2](#)
- Added [Appendix D, One Pulse Per Second Source Connection](#).

What's New In This Guide

Chapter 1 Description

This section contains a description of the X72 and lists its typical applications. It provides information on dimensions, performance, and connector pinouts.

In This Chapter

- [Overview](#)
- [Typical Applications](#)
- [Specifications](#)

Overview

The X72 rubidium (Rb) oscillator is the newest and smallest of Symmetricom's family of precision frequency generator components. This fifth generation Rb oscillator reflects significant advances in physics miniaturization and integration and offers a low height (0.70 inch / 17.7 mm), a small footprint, and an industrial temperature range of -40°C to $+85^{\circ}\text{C}$.



X720001

Figure 1-1 X72 Rubidium Oscillator

Drawing on over 30 years of experience, the X72 design has been refined for low cost mass production and can be easily integrated into time, frequency and synchronization systems, requiring only one input supply voltage. It can be mounted directly onto a circuit board as a component of a module used in 0.8 inch wide card slots. It offers the high reliability and accuracy of a rubidium oscillator in a new design concept benefiting from the many years of experience Symmetricom has gained in fielding tens of thousands of rubidium oscillators.



X720002

Figure 1-2 Size Difference of X72 (top) and Vintage FRK Rb Oscillator

Typical Applications

The elevated operating temperature range of the X72 sets a new high-point for this type of atomic reference. Compared with traditional quartz oscillators, the stability of the X72 allows it to maintain excellent frequency control even when the operating temperature goes above 85° C. Even if the host system overheats in fault mode the X72 oscillator continues to produce a stable and accurate time or frequency reference.

The X72 is easily integrated into time and frequency systems because of its low profile. The height and footprint are designed to accommodate 0.8 inch (4 I) wide card slot applications. The unit operates with a low power requirement (between +10 and 32 Vdc).

This design is being successfully applied as an OEM component in wireless telecom networks such as digital cellular/PCS base stations, SONET/ SDH digital network timing, etc. Linked with a GPS receiver or other external timing reference, the X72 provides the necessary timing requirements for CDMA cellular and PCS systems. The low temperature coefficient and excellent frequency stability extend holdover performance when the GPS signal is not available. Temperature compensated units are available for those special applications requiring even better temperature performance.

The X72's 20-year stability without the need for retuning permits extended operating periods without maintenance (long life Rb lamp, extended crystal control range). The design produces a stable frequency with good short and long term stability, and excellent spur performance.



Note: Symmetricom's commitment to quality and reliability is backed by a 20-year warranty on the physics package (lamp bulb and resonator cell).

The microprocessor-based X72 is a more cost-effective system design that allows serial command selection and enabling of TTL-level digital output frequencies. This allows the oscillator output to be divided to a number of different frequencies, as opposed to older oscillators with a single fixed output frequency. The sine output frequency is selected at time of order.

A 1 PPS output is an integral part of the design. An optional 1 PPS input allows the unit to track a GPS or other external reference, and display the difference between the input and the 1 PPS generated by the X72 through the RS232 link.

For simple applications the X72 provides a 5V CMOS-compatible Built-in Self Test (BIST) Service and a **LOCK** alarm signal derived from the basic physics operation. This lock signal indicates when the output frequency is locked to the atomic resonance of rubidium. When more control over the device is desired, an extensive command control status dialog is available.

In addition to controlling the operation of the oscillator, the microprocessor's built-in firmware allows an external host computer to communicate with the embedded controller through a serial port connection. This allows precise frequency control, the dynamic frequency selection, the ability to enable and disable outputs, to query the system's health, and acquire information about the unit's serial number, operating temperature, fault history, initiate a self test, and other performance indicators. The protocol used is Symmetricom's proprietary Symmetricom Serial Interface Protocol, or SSIP.

The simplified block diagram below shows the importance of the digital control in the unit, how it controls and monitors all aspects of operation, such as the heater circuits of the physics package, as well as the selection of outputs.

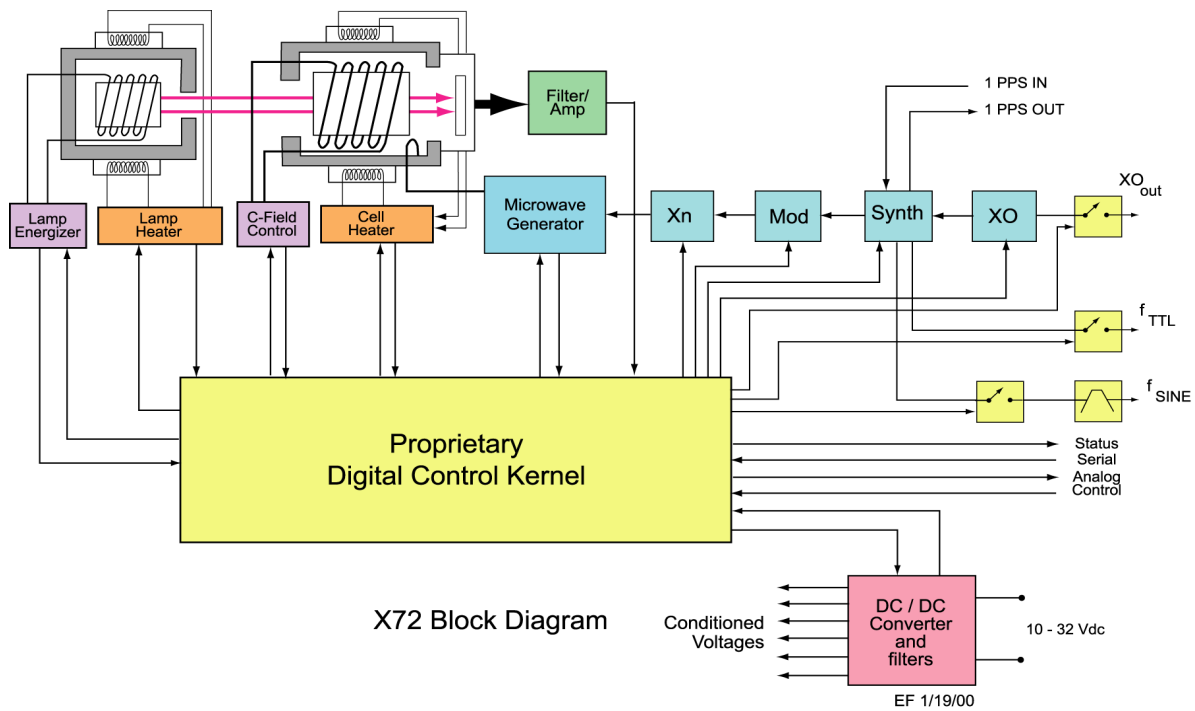

X720003

Figure 1-3 X72 Rubidium oscillator simplified block diagram

Specifications

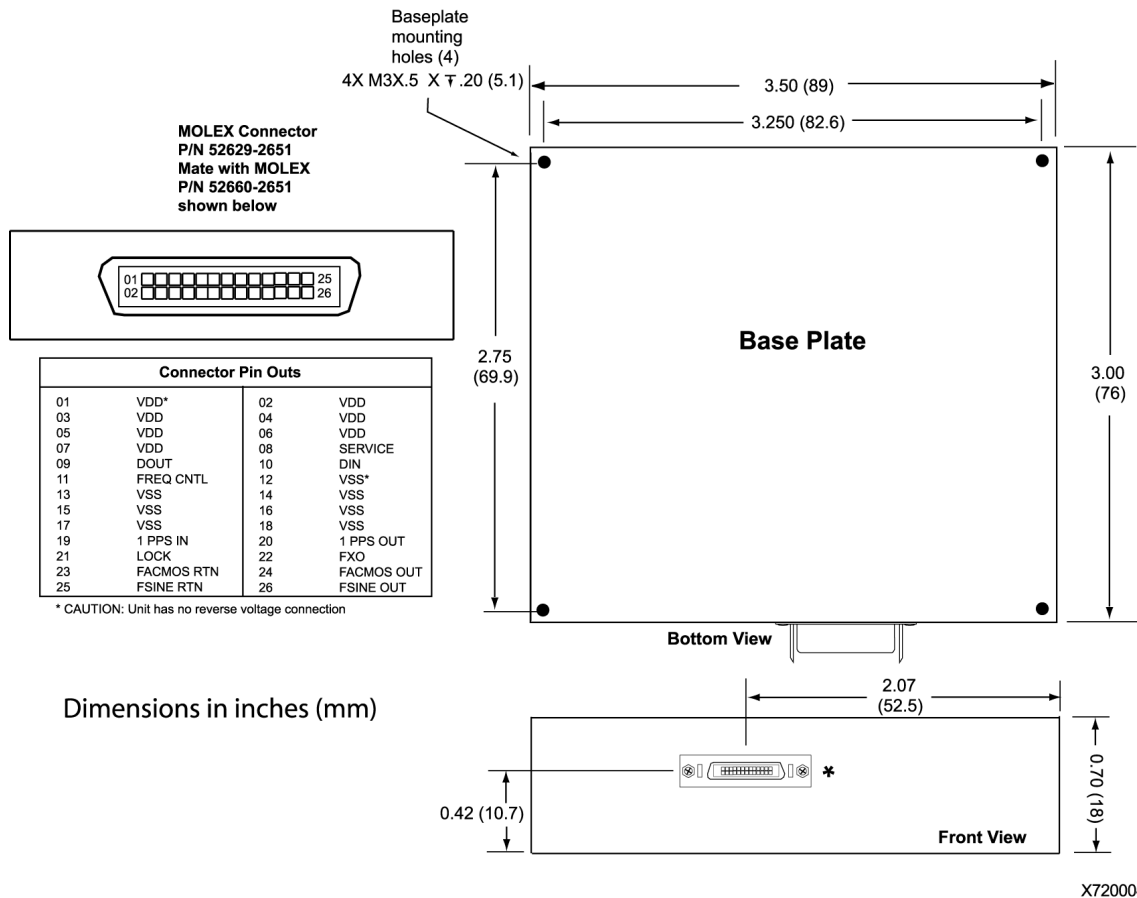

Figure 1-4 X72 Dimensions and Connector Pin Assignments



Caution: To avoid damage to the X72, ensure that power and ground are properly connected. This unit has an internal fuse but has no reverse polarity protection.



Note: All pins on the MOLEX connector must be connected.

Table 1-1. X72 Design Absolute Maximum Ratings

Pin Number	Signal Name	Type ¹	Signal Function
1 – 7	VDD	PWR	+ Power input +10 to +32 Vdc – all power pins must be connected.
8	SERVICE	Output	Indicates unit is nearing limits of frequency control and that Service is required within several months.
9	DOUT	Output	UART data out at AC MOS logic levels.
10	DIN	Input	UART data in at AC MOS logic levels.
11	FREQ CTRL	Analog	Frequency control – analog input between 0 – 5 Vdc.
12 – 18	VSS	GND	– Power & signal return – all grounds must be connected.
19	1 PPS IN	Input	1 PPS input, positive edge triggered.
20	1 PPS OUT	Output	1 PPS output, may be enabled/disabled digitally.
21	LOCK	Output	If low, indicates Rb osc. is locked.
22	FXO	Output ²	(FXO) AC MOS output equalling the VCXO frequency.
23	FAC MOS RTN	GND	Return for FAC MOS & FXO signals.
24	FAC MOS OUT	Output	(FAC MOS) AC MOS output option - equals VCXO frequency divided by 2xN (N is selectable).
25	FSINE RTN	GND	Chassis ground – return signal for FSINE signal.
26	FSINE OUT	Output	(FSINE) Sine output option – equals VCXO frequency divided by 2xM (M is set at the factory).

Note:

1 All inputs and outputs are ESD protected, short circuit protected, and all inputs are compatible with 3.3V AC MOS logic and 5V TTL logic.

2 High impedance



Note: Refer to Appendix A for the connector manufacturer's drawings and specifications.

Table 1-2. X72 Design Absolute Maximum Ratings

Symbol	Characteristic (Unit in ambient still air – convection)		– 40° C to 85° C Base-plate	Units
V _{CC}	Supply relative to ground	10 to 32 volt unit	– 0.25 to 40	
V _{IN}	Input voltage relative to ground regardless of power supply voltage	DIN & 1PPSIN	– 0.5 to 5.5	V
		Frequency control	– 0.5 to 5.5	
P _{WU}	Max Warm Up Power		17	Watts
P _Q	Max quiescent power	– 40° C base plate	15	Watts
		25° C base plate	10	Watts
		85° C base plate	5.0	Watts
t _{wu}	Maximum warm-up time	– 40° C base plate Lock to < 1xE ⁻⁹	<8	Minutes
		25° C base plate Lock to < 1xE ⁻⁹	<4	Minutes
T _{MOBP}	Maximum absolute operating base plate temperature	Conditions: still air – convection – no heat sink on unit	– 45 to 85	° C
T _{MTBP}	Maximum absolute turn-on base plate temperature	Conditions: still air – convection – no heat sink on unit	– 40 to 85	° C
T _{STG}	Maximum Storage Temperature		– 55 to 85	° C
	Maximum vibration (powered but not locked)	Sine – 1 inch DA or 10G	0 to 300	Hz
	Maximum vibration (powered and maintaining lock)	Sine – 1 inch DA or 10G	0 to 100	Hz
	Maximum altitude (powered up unit)	With respect to sea level	30,000	Feet
	Maximum altitude (unpowered)	With respect to sea level	50,000	Feet



Note: All outputs are short circuit protected

Table 1-3. X72 Design Operating Characteristics

Symbol	Characteristic (Unit in ambient still air – convection)	– 40° C to 85° C Base-plate			Units
		Min	Max	Typ	
Digital Inputs/Outputs					
V _{CC}	Supply relative to ground	10 to 32 volt unit	10	32	V
V _{IH}	High level input voltage	DIN	2.5	5.5	V
		1PPSIN	1.8	5.5	
V _{IL}	Low level input voltage	DIN	0	0.8	V
		1PPSIN	0	0.8	
V _{OH}	High level output voltage	DOUT, Service, Lock @IOH = – 0.33 mA @ IOH = 0 mA	3.3		V
		FXO, FACMOS, 1PPSOUT @IOH = – 3.5mA	3.5		
V _{OL}	Low level output voltage	DOUT, Service, Lock @IOL = 0.1 mA	0.4		V
		FXO, FACMOS, 1PPSOUT @IOL = 1.7 ma	0.4		
Analog Inputs/Outputs					
V _{FC}	Frequency control input voltage range	Range of $\pm 1.5 \times 10^{-9}$ with resolution of 2.0×10^{-12}	5		V
P _{SO}	FSINE output power range	Factory set with 7.0 (Output load of 390pF cap & 50 Ω resistor within 4 inches of FSINE pin).	5.0 min. 8.0 max. 6.5 typ.		dBm
Frequency Control					
$\Delta F/F_R$	Control Range	Analog (freq ctrl pin)	-1.5×10^{-9}	+ 1.5	Δ Hz/Hz
		Digital Interface	-1.0×10^{-6}	-1.0×10^{-6}	
$\Delta F/F_{RES}$	Frequency Control Resolution			2.04	$E^{-12} \Delta$ Hz/Hz

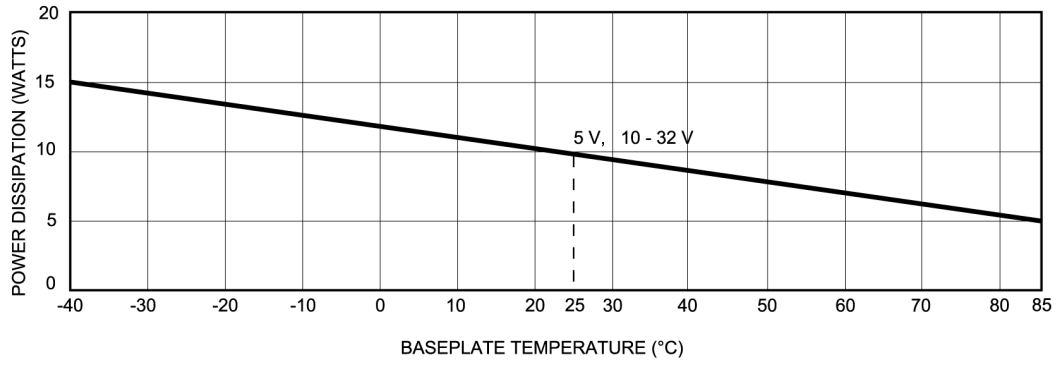

X720005

Figure 1-5 Total X72 Quiescent Power Dissipation, Typical (free convection)



Base plate Temperature (° C)

Figure 1-6 Representative X.72 f/f versus Temperature (uncompensated)



Note: Refer to the X72 Performance Characteristics document for more detailed information.

Description
Specifications

Chapter 2 Design Integration Considerations

This section provides information on mounting and mating connectors, operating temperature, electrical interface, EMI, and noise susceptibility.

In This Chapter

- [Mechanical Considerations](#)
- [Thermal Considerations](#)
- [External Interfaces and Grounding](#)
- [Electrical Interface](#)
- [Frequency Control Analog](#)
- [Modifiable Unit Settings](#)
- [X72 Susceptibility to Input Noise](#)
- [X72 Reliability and Maintenance](#)

Mechanical Considerations

Mounting Recommendations

To mount the X72 to a circuit card or chassis, use the four mounting holes located at the corners of its base plate. An interface cable or adapter card is required to access the X72 outputs and to interface with a host system.

Use four M3 stainless steel screws with a minimum penetration depth of 0.2 inch (5.08 mm) and a maximum of 0.5 inch (12.7 mm) to mount the unit.

Recommended Mating Connectors

Shielded cable must be used between the X72 connector and the host system connector to meet noise and emissions requirements noted in the X72 engineering specifications. It is recommend that for typical applications this interface cable be no longer than 4 inches (10 cm).

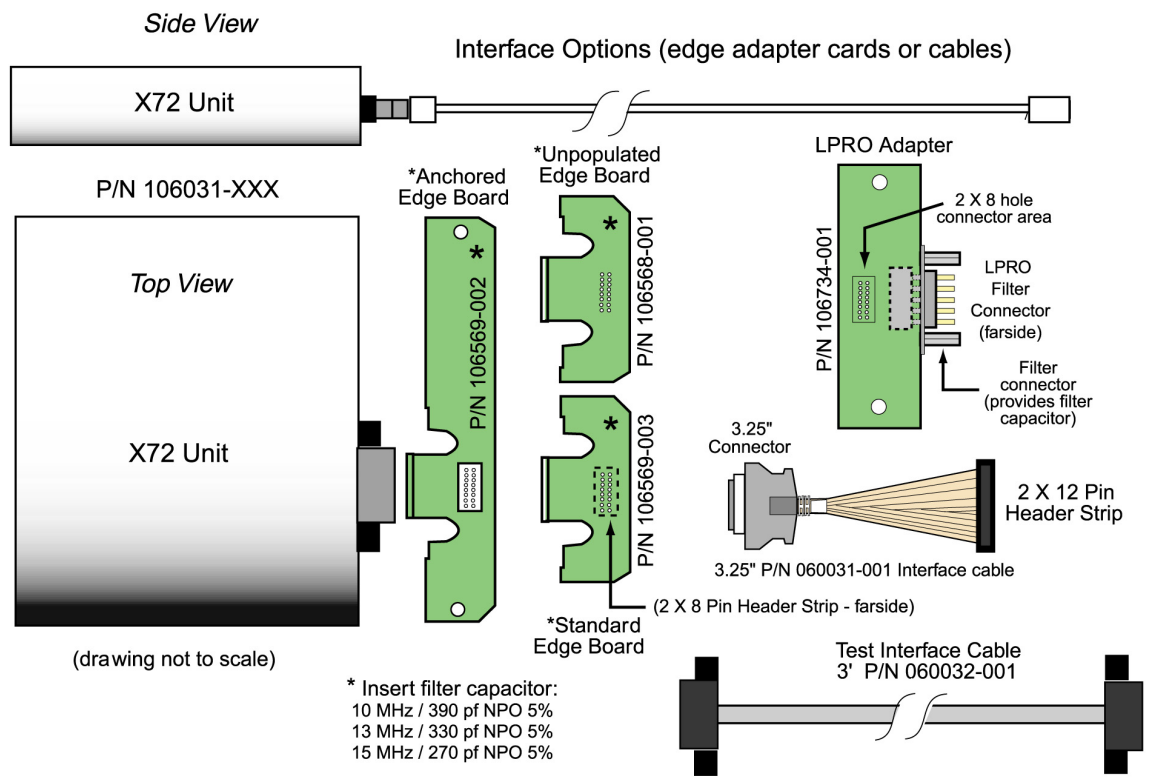

X720006

Figure 2-1 Adapter Cards, Cables, and Options

Integrating the X72 into a System

Symmetricon has developed several integration options to aid the system designer in integrating the X72 into their application. These options provide a variety of connection schemes. Each option is described below.

Unpopulated Edge Board

The Unpopulated Edge Board is a small printed circuit board (PCB) that plugs directly into the X72's Molex connector.

The Unpopulated Edge Board includes unpopulated pads for the following components:

- 16-pin header (See pin out comparison in [Appendix A, X72 J1 Connector and Plug](#))
- Coaxial connector for the Sine Output
- Resistor and Capacitor pads to allow for improved Sine Output dc filtering (See [Electrical Interface](#), on page 36)

From the various interface points on the Edge Board a system designer can access all inputs and outputs of the X72 and can mount the connectors that are necessary for their application. This provides a variety of connection schemes. The examples included in this document are just a few of the integration methods possible with these edge boards.

The Edge Board comes in three different versions: Unpopulated (PN 106568-001), Standard (PN 106569-003), and Anchored (PN 106569-002). The three versions are electrically identical. The Anchored version is 3.5 inches (8.89 cm) long. The Standard and Unpopulated versions are 1.74 inches (4.42 cm) long. Each card has two anchor points (refer to [Figure 2-2](#), [Figure 2-3](#), and [Figure 2-5](#)). In addition, the standard edge board includes the header that is mounted directly to the PCB by direct solder connection or by plugging into a socket provided by the user.

Refer to [Figure A-3](#) in [Appendix A, X72 J1 Connector and Plug](#) for a schematic of the connector pinouts.

Unpopulated Edge Board

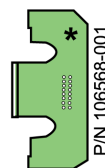

* Insert filter capacitor:
10 MHz / 390 pf NPO 5%
13 MHz / 330 pf NPO 5%
15 MHz / 270 pf NPO 5%

X720007

Figure 2-2 Unpopulated Edge Board

Standard Edge Board

The Standard Edge Board version (PN 106569-003) is intended for implementations where the Edge Board is connected directly into the system board by soldering directly to the PCB or plugging into a socket provided by the user (see example below). The Edge Board achieves its mechanical stability from the direct connection.

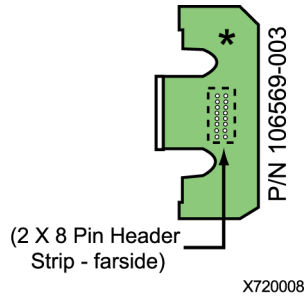

Figure 2-3 Standard Edge Board

The Standard Edge Board includes the following:

- 390 pf capacitor
- 10 Ω resistor
- 15 μ F capacitor
- Pad for coaxial connector for sine output
- Soldered 2 x 8 pin connector
- Adapter for connection to PCB



Standard Edge Board

X720009

Figure 2-4 Standard Edge Board Mounting Example

The Anchored Edge Board

The Anchored Edge Board (PN 106569-002) can be used in applications where the Edge Board is not plugged into a PCB and does not have a solid electrical connection such as a soldered header that can keep the Edge Board in place in harsh vibration environments. Two anchor points are provided to accommodate these applications.

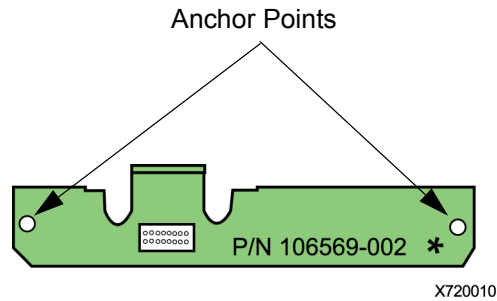

Figure 2-5 Anchored Edge Board

The Anchored Edge Board includes the following:

- 390 pf capacitor
- 10 Ω resistor
- 15 μ F capacitor
- Pad for coaxial connector for sine output
- Unpopulated 16 pin header strip for customer integration.



X720011

Figure 2-6 Anchored Edge Board Mounting Example

3.25 Connector

The 3.25 inch connector (PN 060031-001) is an all-in-one connection option that includes the mating connector to the X72 and a 24-pin header that can be mounted directly on a system board. The flexible cabling allows the header to be installed in various orientations to the unit.

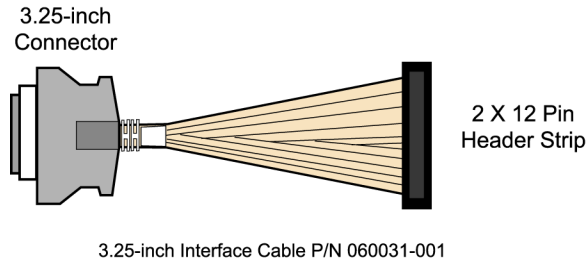

X720012

Figure 2-7 3.25-Inch Connector and Header

3.25 Connector Mounting Example

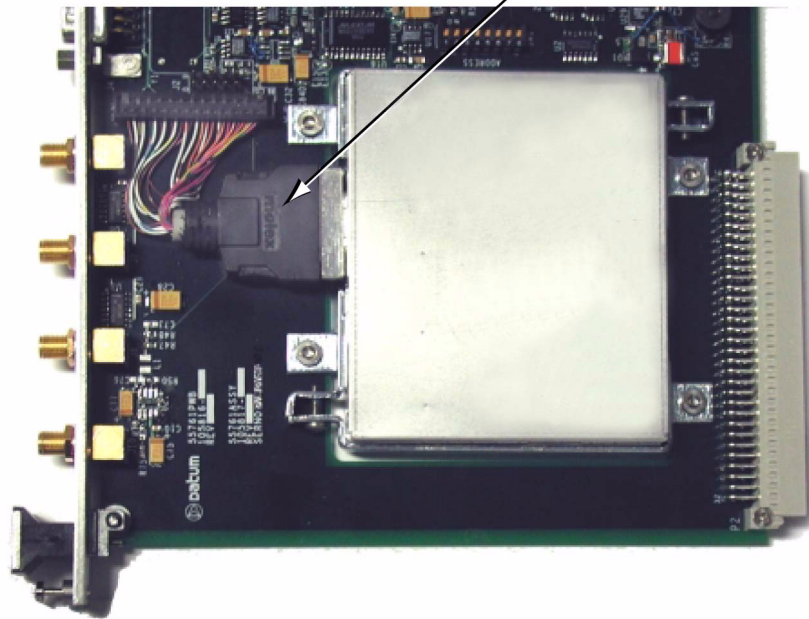

X720013

Figure 2-8 3.25-Inch Connector Mounting Example

X72-LPRO Adapter

The X72-LPRO Adapter (PN 106734-001) was developed for existing Symmetricom LPRO customers. The Symmetricom LPRO Low-Profile Rubidium Oscillator is the most widely produced rubidium oscillator in the world and has been designed into hundreds of applications. The X72-LPRO Adapter allows these customers to upgrade to the X72 without changing the physical interface in their unit.

The Standard Edge Board and the LPRO Compatible Option Board both have sockets to install and solder a 2 x 8 pin connector between the two boards. The LPRO filter connector does not require the installation of a filter capacitor since it was designed to provide a filtering function.

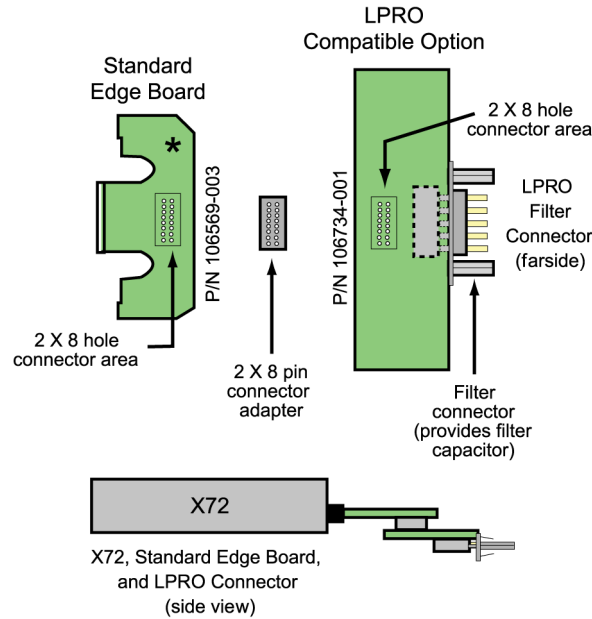

X720014

Figure 2-9 Standard Edge Board and LPRO Connector

Thermal Considerations

Thermal Tape

In order to achieve the highest ambient operating temperature for the X72 operating base plate temperature Symmetricom recommends that the bottom (“base plate”) of the X72 have good thermal contact to the mounting surface. It is also very important to maintain a uniform temperature into the base plate of the X72 through its mounting points. The X72 unit operates normally without thermal tape. In some field applications the tape may simplify customer system thermal design requirements.



Warning: To avoid personal injury, attach the X72 to a heat sink to prevent it from becoming too hot to touch.

The X72 maximum base plate temperature described in the specifications is based on a unit covered on five sides with one inch foam to simulate free convection in air with the heat sink/base plate exposed to forced air.

If there is air flow over the unit's top cover, the X72's maximum operating base plate temperature increases by 1 or 2° C and its power consumption at a given base plate temperature also increases by a few tens of milliwatts.

As the base plate temperature continues to increase the unit eventually loses lock. Above a base plate temperature of +85° C the resonator or lamp heaters shut down as control point temperatures are exceeded and the unit temperature coefficients increase to approximately 6×10^{-10} C.

Water Condensation and Excessive Humidity

Condensation of moisture from the air onto electrical components produces frequency spikes or instability until the heat of the operating unit drives out the water vapor.

Condensation will not cause a problem for environments meeting the X72 specification if the X72 base plate thermal ramp rates are controlled so that they rise at less than 2° C/minute.

Excessive Dust

Operating the unit in dusty conditions may cause unexpected thermal effects if dust builds up on the top surface. Excessive dust will also contribute to contamination in the shell of the mating connector and could cause intermittent loss of signals.

The X72 is shipped in a dust-protected ESD resistant bag. All connectors on any product must be suitably protected, before mating, in a dust-controlled environment.

External Interfaces and Grounding

Figure 2-1 shows the interface circuitry for J1, the X72 I/O connector. All signals, including power, power return, rf output, signal/chassis ground, and monitor lines are routed through this connector. All voltage supply and ground lines must be connected at the mating connector for the X72 unit to operate properly.

The X72 is constructed with the chassis (unit cover) and signal grounds tied together at multiple points, and with the power supply return isolated from both chassis and signal grounds only by a ferrite bead. This robust grounding approach allows for ESD protection and low spurious emissions. But it can also lead to ground loop issues for the user.

Workarounds commonly used to break dc ground loops at a higher level of integration are to use an rf isolation transformer for the sine rf output, and/or float the transformer secondary winding of the user's power supply.

Electrical Interface

X72 RF Outputs

RF Output Impedance versus Frequency

The active rf output impedance for the X72 is a nominal 50 Ω at 10 MHz, but is a widely varying impedance at other frequencies. You must take this into consideration if the X72 rf output is driving a non-buffered filter. Note that the X72 is specified as delivering 0.5 V_{rms} (typical) into a 50 Ω resistance load. Loads that present complex impedance or resonances affect signal amplitude. The X72 can drive a properly terminated transmission line of 50 Ω characteristic impedance.



Note: A 390 pF capacitor from the 10 MHz sine output to the sine return is required within four inches of the output connector. It can be located across the 50 Ω terminator (see [Figure 2-1](#)).

If the sine output port is disabled its characteristic impedance remains the same.

AC-Coupled RF Load

The X72 is designed to tolerate an ac-coupled rf load without waveform distortion provided the coupling capacitor is low impedance at 10 MHz (for example, a 0.01 μ F capacitor has an X_c of 1.6 Ω , which is small compared to the 50 Ω nominal output impedance). The rf output stage of the X72 uses an ac-coupled design.

Symmetricon recommends that you use a ceramic coupling capacitor with an X7R or NPO dielectric.

Transformer-coupled RF Load

The transformer-coupled rf load is used to break up ground loops. It can also be used to provide some bandpass filtering. However, it also attenuates the rf signal, making it difficult to provide a tight tolerance on the rf output level. It is also difficult to obtain an inexpensive, off-the-shelf wide operating temperature range SMT rf transformer.

X72 1 PPS Input and Output

The 1 PPS output signal of the X72 unit is positive-edge triggered and gated with the rising edge of the clock. Its duration for a 10 MHz unit is 400 ns \pm 10%. Rise/fall time is 4 ns.

The 1 PPS is exactly divided from the XO frequency.

Lock Signal

The LOCK signal indicates that the internal Voltage Controlled Crystal Oscillator (VCXO) is locked to the atomic transition. If the Lock signal is LOW once warm-up is completed, the output frequency is locked to the Rb atomic clock.

If the LOCK signal is high, atomic lock has been lost and the X72 goes into sweep mode to reacquire lock. The sweep ranges from approximately -21 ppm to $+21$ ppm in approximately a 20 second period. During the sweep, outputs are maintained but you should not rely on signal accuracy during sweeping. If the power source to the X72 is OFF, the lock output line is low.

Service Signal

The Service Signal is valid when the unit is operating and the rubidium oscillator is locked.

The Service Signal algorithm monitors the health of the Rb physics package, which includes the Rb lamp bulb and resonator cell, and the unit's crystal oscillator that is slaved to the Rb atomic clock.

The Service Signal indicates low when any of the internal operating parameters are near the end of their tuning or adjustment range, providing a month's warning of this situation.

X72 Frequency Control Signal

The X72 frequency control signal is an analog input between 0 and 5 Vdc that can be enabled or disabled at the factory (making it a default setting) or by the customer at a later date (using the SSIP). The Service BIT can be selectable high or low.

When in use, the smallest incremental frequency change is 2×10^{-12} (or f.2). The unit always powers up to the preset free running factory set frequency. Adjustments to the frequency are always relative to the free running frequency of the unit (see also [Frequency Control Analog](#), on page 38).

X72 ACMOS Output Frequency

The ACMOS output frequency is equal to the crystal frequency divided by $2N$ (N is a number from 1 to 65536). For example, the SSIP command to modify the output of the VCXO for an output of 10 MHz from a 60 MHz XO is "o3".

Frequency Control Analog

Greater Than $\pm 1 \times 10^{-9}$ Internal or External Control

The external frequency control circuitry is designed so that with no voltage applied at J-11, the voltage will self bias to mid-range, or 2.5V. This input can also be turned off via the SSIP to eliminate any source of noise. In some versions of the X72, this function can be turned off by customer request on power up. If it is to be used later it must be enabled through the SSIP (refer to [Appendix B, Symmetricom Serial Interface Protocol](#)).

Time Response of External Frequency Control

The external analog frequency control is a sampled input with a typical response time constant of 154 ms.

Temperature Compensation of Frequency

One of the key specifications for an atomic frequency standard is the temperature coefficient. The X72 is designed for a low temperature coefficient without the need for temperature correction. However, if the application requires a tighter temperature coefficient and a more automated temperature compensated unit was not ordered, you can monitor the base plate temperature of the X72 and apply a correction signal via the External frequency control pin, or through the SSIP. A production calibration run is required to set the X72 temperature at several points and determine the correction summary.

This method can be successfully used for moderate correction, for example to bring the maximum frequency change over the full operating temperature range to less than 1×10^{-10} .

Compensation using this scheme is generally suitable only for steady state conditions. Inherent mismatches between the thermal time constants of the mechanisms that cause temperature coefficient errors, thermal time constant of the monitoring circuitry, and transients from time constant mismatches will occur. These transients are minimized if temperature ramp rates are limited. Changing less than $+2^\circ \text{C/minute}$ base plate temperature should result in negligible transients from mismatches.

Modifiable Unit Settings

You can modify some features of the X72 operation are modifiable by the customer. Refer to the X72 Developer's Kit document (DK/106031) for information on how to use the SSIP to use these functions.



Note: You cannot alter the default power up conditions.

Table 2-1. Hardware Selectable Items

Item	Action
FXO Enable	Turn the XO frequency output on or off
1PPS Output Enable	Turn 1PPS output on or off
ACMOS Output Enable	Turn the ACMOS output on or off
Sine Output Enable	Turn the sine outputs on or off

Table 2-2. Software Selectable Items

Item	Action
Analog Frequency Adjust	Enable or disable frequency control function
Adjust Frequency ¹	Adjust output frequency from the factory preset value
HELP	Displays the HELP menu
Change ACMOS output frequency	Defining "N" sets the ACMOS output frequency divider
View Control Register	Displays current settings of the control register
Set Control Register	Enable or disable outputs
View Unit Information	Displays X72 information stored in firmware
View Health Monitor Data	Displays history file of error or fault information

Note:

¹ Minimum frequency change is $2 \times E^{-12}$ (or "f.2"). Values less than this are ignored. Maximum frequency change, is not constrained. Setting the frequency outside of its operating limits may render the unit non-functional.

X72 Susceptibility to Input Noise

If you have an application where the output spectrum phase noise and spur integrity is crucial, the X72 must have a comparatively clean source of dc power (free of spurious current or voltage noise). Connecting fans, heaters, and other switching devices to the dc supply powering the X72 can result in degraded phase noise and spur performance. Best performance is achieved with only one output turned on and the other frequency outputs turned off.

The Rb atomic frequency source uses a modulation/demodulation lock-in amplifier scheme with a modulation frequency of approximately 156 Hz. Inherent in this approach is sensitivity to noise at multiples of the modulation frequency. This noise is coupled through both the heater and electronic power lines to cause modulation spurs on the output frequency.



Note: Avoid the modulation frequency and its lower harmonics (roughly up to the tenth harmonic).

The X72 has an internal dc to dc converter supplying power to the critical electronics, including the crystal oscillator, which is the source for the outputs.

Input Filtering

If filtering is added at the input connector of the X72, it cannot have resonance points greater than the specified impedance. This would result in peaking the potential for detrimental oscillations. The optimum filtering is less than 1Ω from dc to 100 kHz.

In addition, the input operating voltage range specified for the X72 during turn-on must continue to be met during operation of the unit. For example, using a 1Ω dc source resistance for the input supply line would not be appropriate. The voltage drop resulting from this resistance (caused by the turn-on current or quiescent operating current) would cause the input voltage to drop below the allowable value.

X72 Reliability and Maintenance

Reliability

The X72 is designed with a goal of twenty years of operation without retuning. To accomplish this, the major mechanisms impacting the need for maintenance were addressed. Thus, each X72 has been designed to have excess rubidium fill in the lamp to last for the required period, sufficient pulling range for the voltage controlled crystal oscillator, and sufficient dynamic range of the rubidium control loop.

Maintenance

User Maintenance

The X72 is considered to be factory serviceable only. There is no user service adjustment or maintenance required.

A monitor signal is provided to allow the user to track indications of pending end-of-life for the unit with sufficient warning to avoid a total and sudden failure of the unit. The key indicator of health is the service indicator that indicates when the Rb physics package or on-board quartz oscillator are near their operating or control limits.

If the Lock signal does not indicate a Rb lock within the specified time, or the Service signal indicates that the unit has reached the end of its effective life, remove the unit and return to Symmetricom for service. The Service indicator is valid only when the Lock signal indicates that the unit is locked.

For information on how to return a unit for service, see [Repairs](#), on page 48.

Chapter 3 Installation and Operation

This section provides information on details to consider when installing the X72 and the procedure to follow when turning on the unit. There is an explanation of the start-up sequence, monitoring performance, and theory of operation. It also contains a troubleshooting guide, customer support information, and warranty information.

In This Chapter

- [Installation](#)
- [Start-up Sequence](#)
- [Theory of Operation](#)
- [Troubleshooting](#)
- [Repairs](#)

Installation

Site Selection

The X72 can be mounted in any orientation. In environments that approach the operating limits of the X72, ensure that the temperature limits are not exceeded.

The X72 is sensitive to external dc and ac magnetic fields (refer to specification) and should not be installed in locations subjected to strong magnetic fields from transformers or large power supplies. An external magnetic field under 2 gauss should not result in measurable frequency offsets for X72.

A Rb frequency standard is a very precise component and you should employ optimum practices for its use. Avoid using a power source that is also providing power to fans or equipment that generates high current pulses.

Turn-on Procedure

Use the following steps to power up the X72.



Caution: To avoid damage to the X72, do not apply power to the unit in reversed direction. The X72 has no reverse voltage protection.

1. Verify the X72 voltage requirement (10 to 32V).
2. Verify that the power supply is set to the correct voltage and is turned off.
3. Connect J1 of the X72 to a properly terminated, shielded cable that does not have power applied.
4. Once the unit has been properly terminated, turn on power.

Refer to [Figure 3-1](#) for a block diagram of a suggested hook-up.

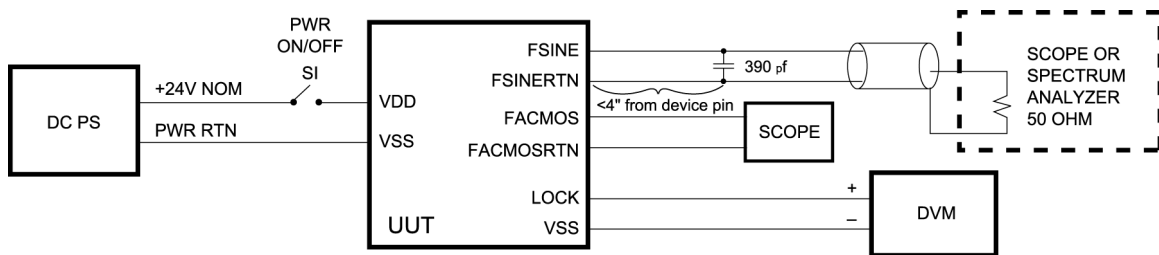

X720015

Figure 3-1 Suggested Connections for X72, Initial Turn-on.

Once the X72 is plugged in and is receiving power, wait 3 to 4 minutes while the unit achieves atomic lock. During this period, the monitored LOCK signal should be HIGH. Once the unit achieves atomic lock, the LOCK signal goes LOW.

Depending on base plate temperature, within 4 to 8 minutes the unit should be within 1×10^{-9} of center frequency. Thirty minutes after applying power to the X72 the rf output frequency will be very close to full accuracy (refer to X72 specifications).



Note: The output frequency of the X72 is more accurate than most counters. Appropriate measurement equipment can be obtained from Symmetricom. Inquire with Symmetricom Marketing, or your local sales representative, about Symmetricom's line of test and measurement standards, which includes the PRFS and FMS-2001.

Start-up Sequence

When power is connected to connector J1, the X72 begins its warm-up cycle. After four minutes the rubidium oscillator reaches a locked condition and its output signals will stabilize. The accuracy at shipment is $< \pm 5 \times 10^{-11}$ at 25° C, typical.



Note: Signals appear at the outputs immediately after power is applied to the unit, but these output signals are not stable until after the oscillator has locked.

After 7.5 minutes the accuracy of the X72 oscillator is $< 1 \times 10^{-9}$. Performance of the X72 unit varies according to the application profile specified by the customer at time of order. Refer to the X72 product specification for information on application profiles and unit performance.

To monitor performance and selectively modify it using the SSIP firmware included in the unit, connect the unit to the COM port of a PC running Windows.

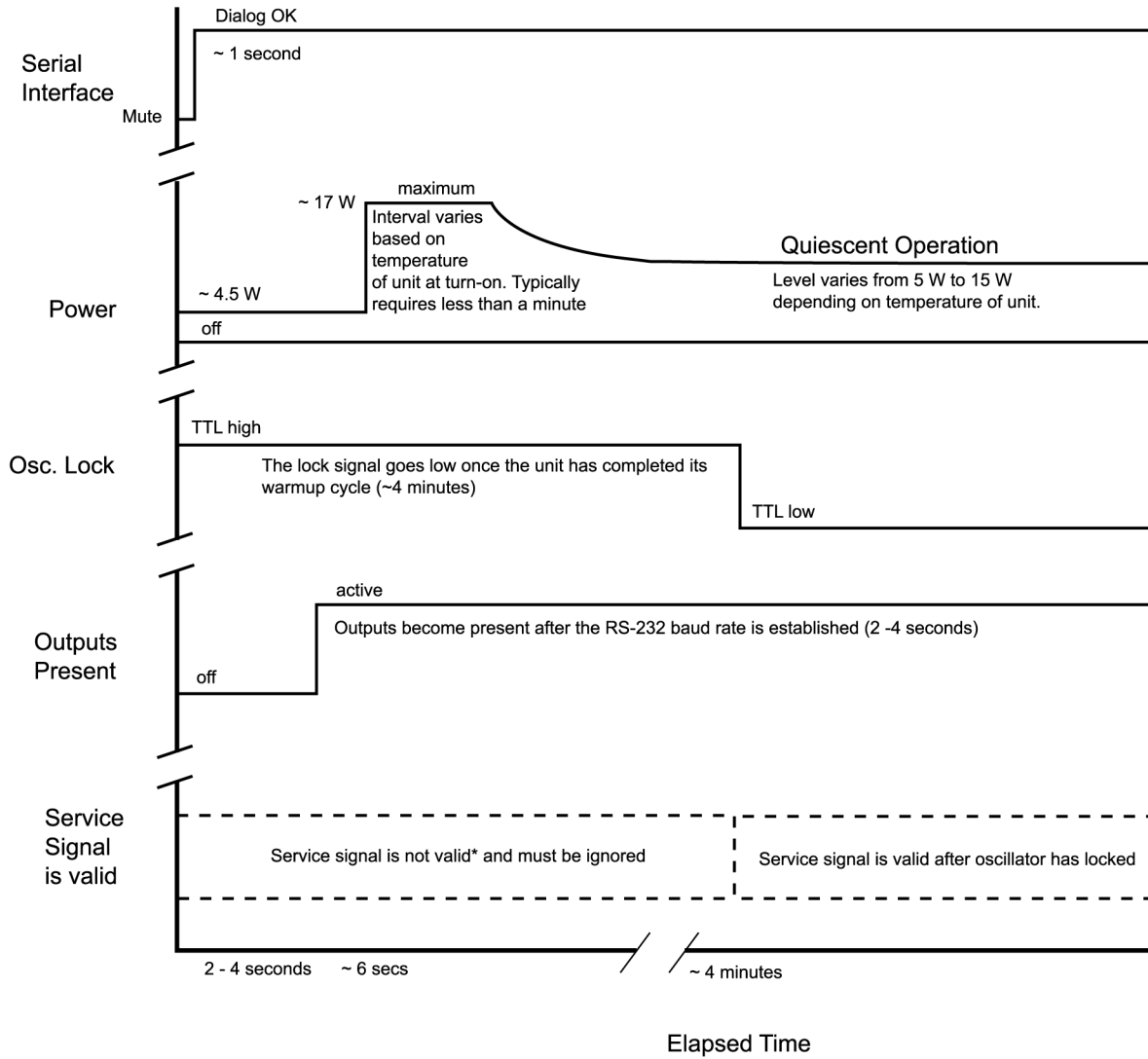

X720016

Figure 3-2 Sequence of Start-up Events



Note: The Service signal can be Active High or Active Low depending on the unit configuration.

Theory of Operation

The Model X72 makes use of the atomic resonance property of rubidium (^{87}Rb) to control the frequency of a quartz crystal oscillator via a frequency-locked loop (FLL).

The FLL function block is shown in Figure 3-3. A microwave signal is derived from a voltage-controlled crystal oscillator (VCXO) and applied to the ^{87}Rb vapor within a glass cell. The light of a rubidium lamp also passes through this cell and illuminates a photo detector. When the frequency of the applied rf signal corresponds to the frequency of the ground-state hyperfine transition of the ^{87}Rb atom (an ultra-stable high-Q rubidium atomic resonance), light is absorbed causing a change (decrease) in photo detector current (I_{PH}).

As the change in current is small, modulation techniques are required to be able to extract the desired signal out of the noise background.

The photo detector current is used to generate a control signal with phase and amplitude information, which permits continuous regulation of the VCXO frequency. The servo section converts the photo detector current into a voltage, then amplifies, demodulates, and integrates it for high dc servo loop gain.

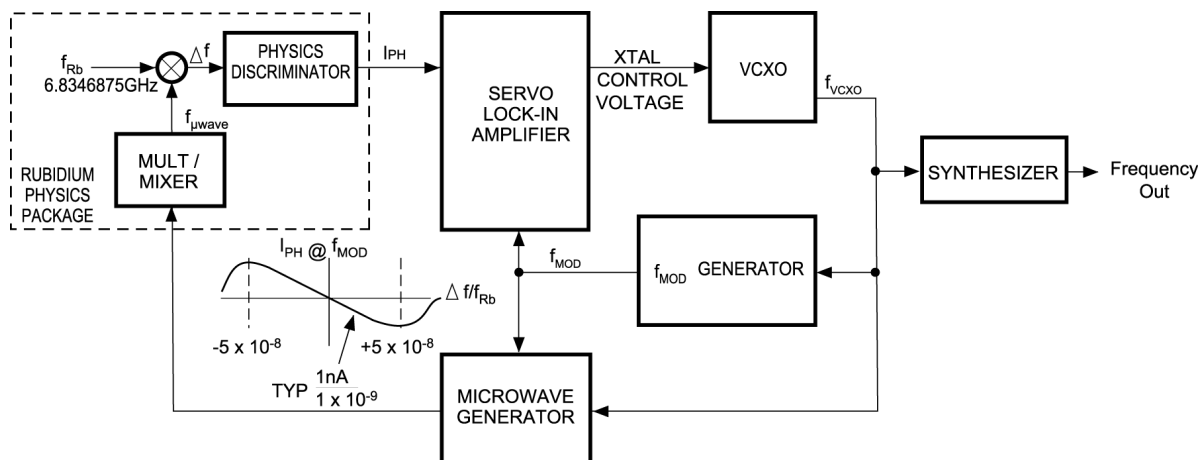

X720017

Figure 3-3 X72 Rb Control Loop Block Diagram

Troubleshooting

After installation, if the X72 unit fails to provide outputs, or the rubidium oscillator fails to achieve lock, check the following:

- The external power supply is providing power
- The external power supply is providing the correct power
- The interface cable may be defective – perform a continuity check



Note: All pins must have a connection in the cable's Molex connectors. This is especially important in the case of the power and ground pins.

- Is there excess humidity or moisture inside the operating area
- Is the ambient temperature below -40°C or above $+85^{\circ}\text{C}$ (the unit will not startup properly in excessively cold or hot temperatures)

Repairs

The X72 is not field repairable, but some firmware upgrades can be done in the field, as noted in [Start-up Sequence](#), on page 45. If the unit should fail, do not remove the cover of the unit and attempt to make repairs.



Note: Unit warranty is void if the cover is removed or if the protective seals covering the two tuning and adjustment holes are torn or removed.

If the unit no longer operates properly, or if it has reached the end of its effective life, please visit Symmetricom's web site at www.symmetricom.com and click the support, warranty and repair link. You can also type the following link into your computer:

www.symmetricom.com/support/warranty_and_repair/repair_form.aspx?prodtype=TSD.

Once you submit your form through the Internet, a confirmation will be sent back to you. Requests are processed within 24 to 48 hours. Once processed, you will receive an e-mail from the Repair Administration group that provides your RMA number, warranty information or repair cost if applicable, and the address of where to send the unit for repair.

If you have questions regarding the status of your RMA you may reach our Repair Administration department at 888 367 7966, option 3. You may also e-mail your requests or queries to TSDRMA@Symmetricom.com. Our fax number is 559 961 5175.

X72 Warranty

Symmetricom warrants the X72 electronics for one year, and the Rb lamp bulb and resonator cell for 20 years. Symmetricom also warrants that at the time of shipment the X72 will be free from defects in materials furnished and workmanship performed by Symmetricom. This warranty and Symmetricom's liability are limited to either granting credit or repairing or replacing, at seller's option, with reasonable promptness after return to Symmetricom of any article that is disclosed to Symmetricom's satisfaction to be defective, and only if said article is returned to Symmetricom promptly after discovery of such defect and in no event later than **12 months** (or such other time period as may be specified in writing as a warranty period for a particular article) from the date of delivery thereof. Normal transportation charges in connection with an article returned shall be at the Symmetricom's expense, but only if Symmetricom is responsible under the terms of this warranty. This warranty does not extend to any article which has been subject to misuse, neglect, or accident, nor does it extend to any article which has been repaired or altered by other than the seller, or operated outside the published maximum temperature ratings.

THIS WARRANTY IS IN LIEU OF ALL OTHER WARRANTIES EXPRESSED OR IMPLIED, INCLUDING ANY WARRANTY OF FITNESS FOR A PARTICULAR PURPOSE AND THE RIGHTS AND REMEDIES PROVIDED HEREIN ARE EXCLUSIVE AND IN LIEU OF ANY OTHER RIGHTS OR REMEDIES. IN NO EVENT SHALL SELLER BE LIABLE FOR CONSEQUENTIAL DAMAGES."

Appendix A X72 J1 Connector and Plug

This appendix provides information on the Molex connector and plug, the edge board pinout and layout, and the 3.25 inch interface cable.

In This Appendix

- [Molex Connector](#)
- [Molex Connector Plug Assembly](#)
- [Edge Board Pinout](#)
- [3.25 Inch Interface Cable](#)
- [Edge Board Layout Drawing](#)

Molex Connector

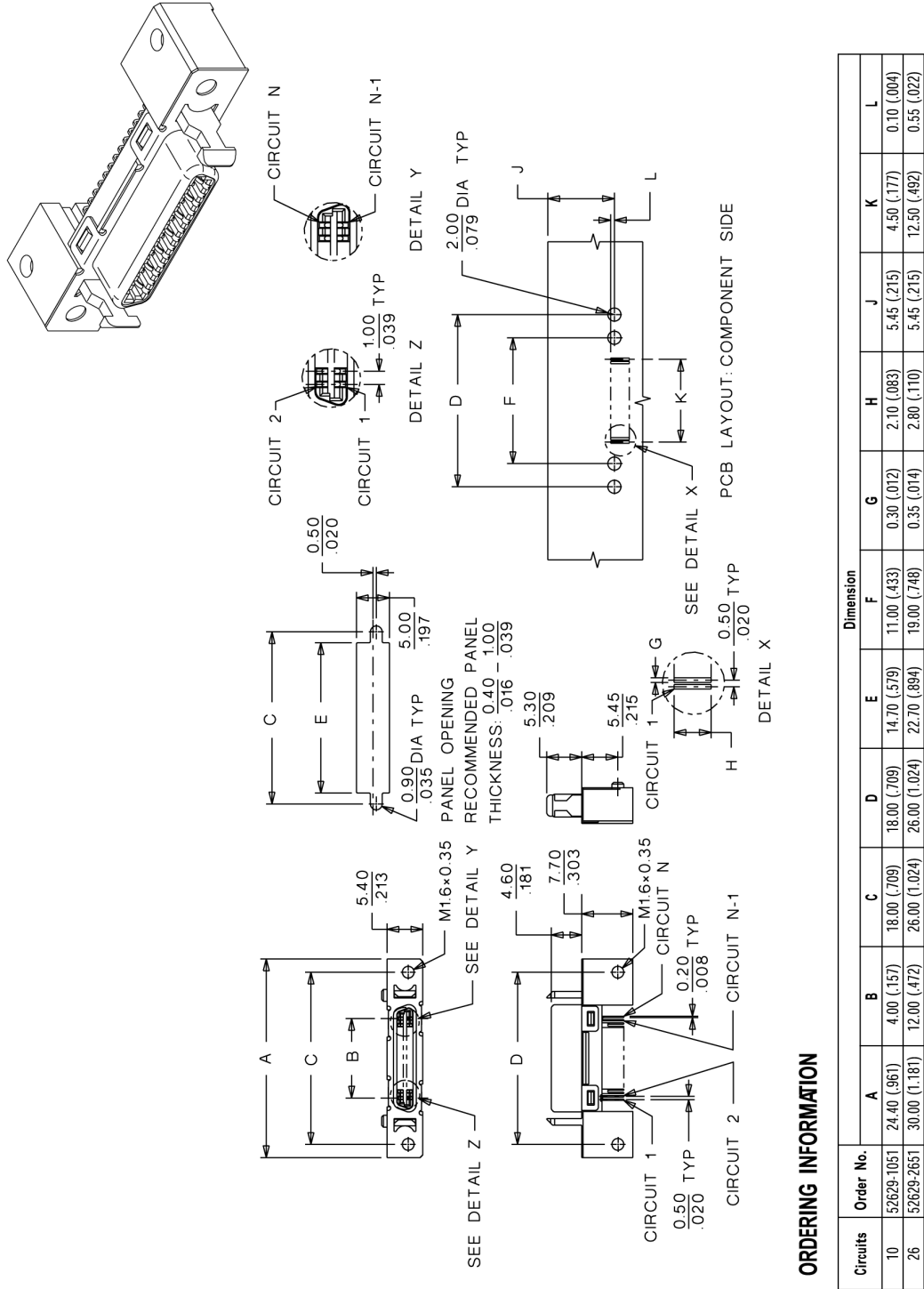

X720018

Figure A-1 Molex Connector

Molex Connector Plug Assembly

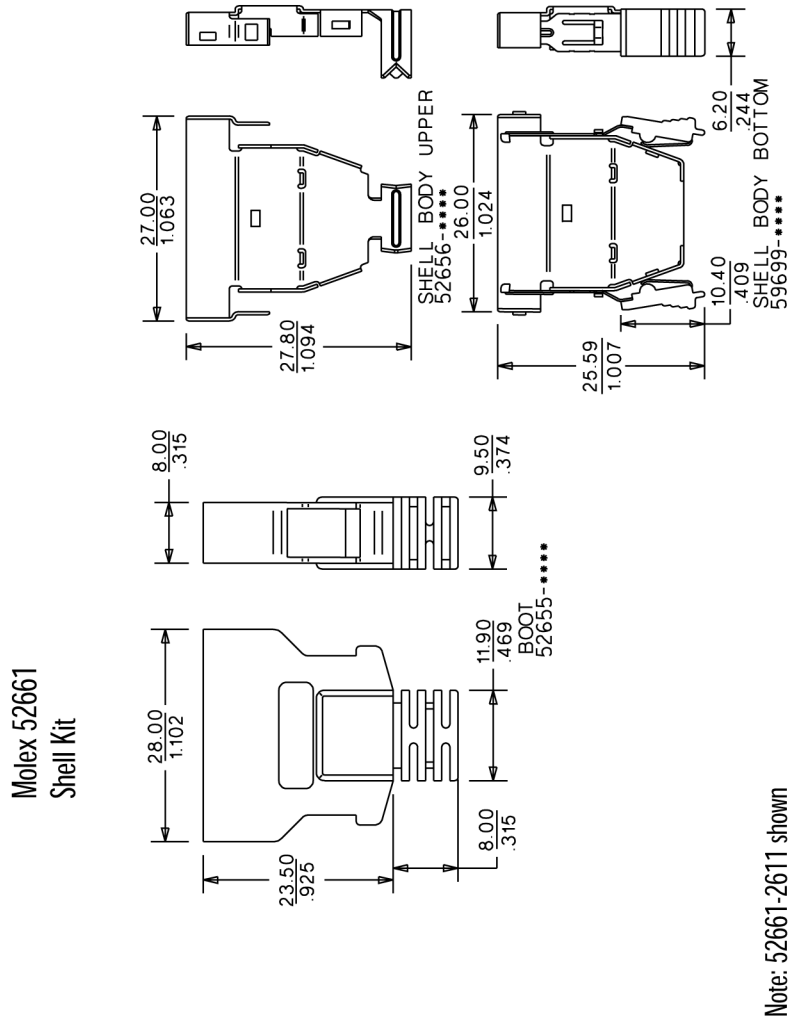

Figure A-2 Molex Connector Plug Assembly

X720019

Edge Board Pinout

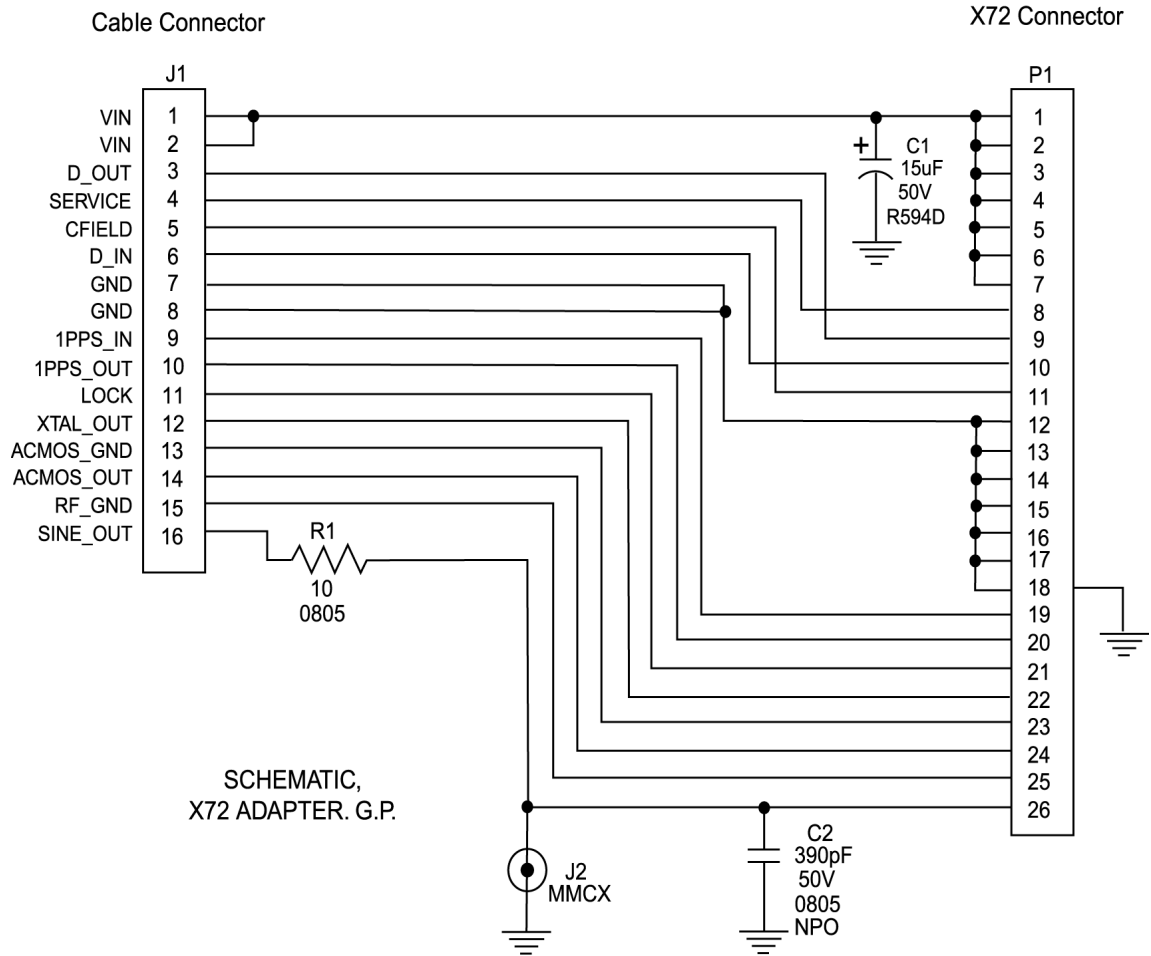
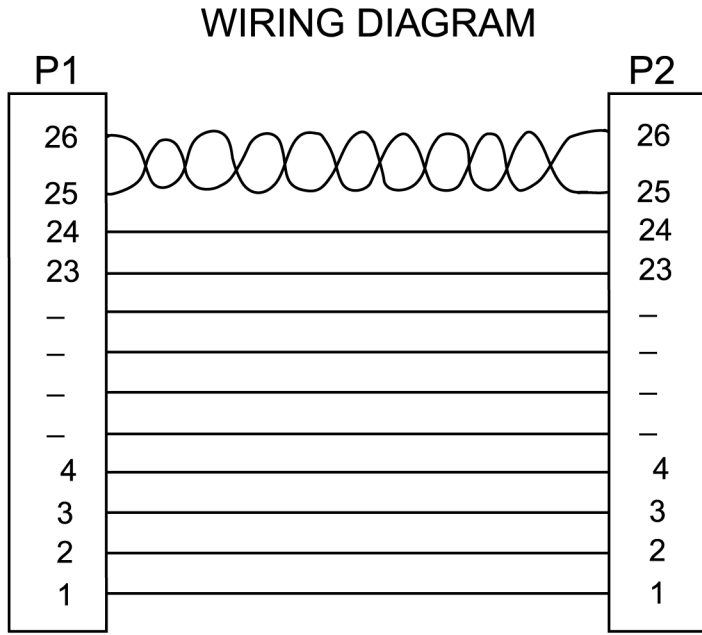

Figure A-3 Edge Board Pinout Comparison

3.25 Inch Interface Cable

WIRING CHART	
P1	P2
1	1
2	2
3	3
4	4
5	5
6	6
7	7
8	8
9	9
10	10
11	11
12	12
13	13
14	14
15	15
16	16
17	17
18	18
19	19
20	20
21	21
22	22
23	23
24	24
25	25
26	26



NOTE:

PINS 25 & 26 TWISTED 3 TURNS/INCH

X720021

Figure A-4 3.25 Inch Interface Cable Connections

Edge Board Layout Drawing

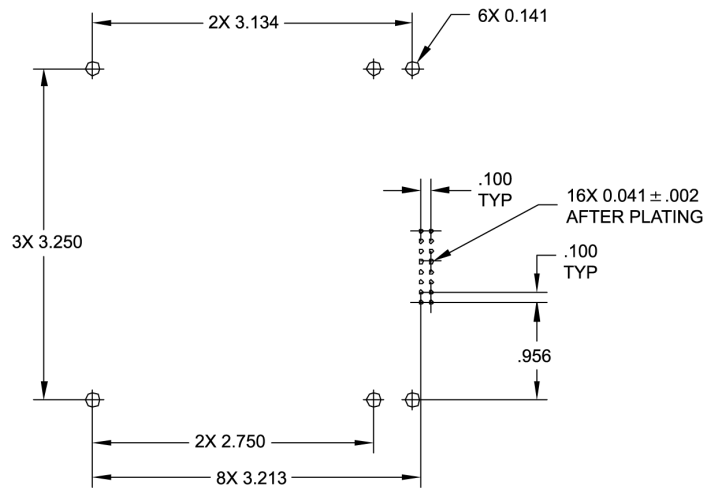

SUGGESTED PCB LAYOUT

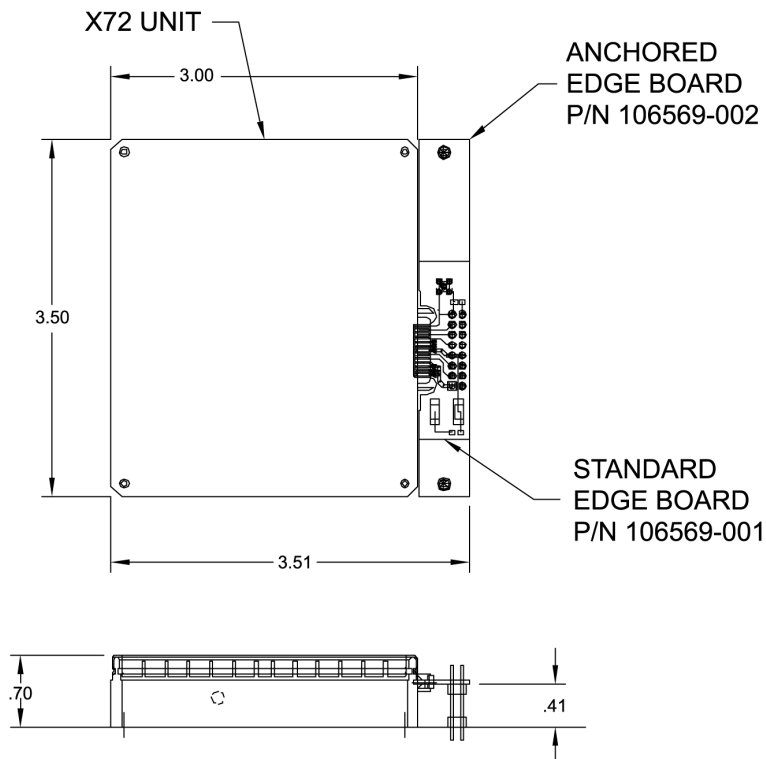

X720022

Figure A-5 Layout Drawing for Edge Board

Appendix B Symmetricom Serial Interface Protocol

This appendix provides information on communicating with the X72 through serial port J1. It includes output examples and a description of commands.

In This Appendix

- [Using the Symmetricom Serial Interface Protocol](#)

Using the Symmetricom Serial Interface Protocol

The Symmetricom Serial Interface Protocol (SSIP) permits external communication with the X72 through the serial port connector J1 when the unit is connected to a host PC. All “developer-mode” commands are a single ASCII letter and require no termination. Of the eight RUN MODE commands, three require the host to supply data.

Host Terminal Emulator Setup

Set up the comm port of the PC with the following configuration:

- Data rate (baud or B.P.S. – baud rate) of the X72 is 57.6K
- No parity
- 8 data bits
- 1 stop bit
- No local echo (unit echoes)
- No hardware or software flow control



Note: The X72's UART connections are based on 5 Vdc logic levels. However, the Developer's Kit contains a TTL-to-RS232 converter that allows interfacing to a PC.

Data Format

Run Mode Data Format (Customer Mode)

X72 outputs are all decimal data as “ASCII Coded Hex” except for echoed characters. Do not convert data to decimal when transmitting to the X72. All data are sent to the X72 and received back as “ASCII Coded Hex”. The following example shows how data are encoded.



Note: Flow control is not permitted in “Run Mode”.

Data sent to the X72 in run mode should not be encoded.

The following is an example of output from the X72 after power is applied to the unit.

```
X72 by Symmetricom, Inc., Copyright 2001
      SDCP Version 3.75 of 3/2001; Loader Version 2
      Mode CNN1 Flag 0004 [822F]ok

Unit serial code is 0009AB001B-h, current tuning state is 6
Crystal: 60000000hz, ACMOS: 10000000.0hz, Sine: 10000000.0hz
Ctl Reg: 029C, Res temp off: -1.5410, Lamp Temp off: -2.1142
FC: Enabled
Srcv: high

Enter Run Mode
FC Mode is enabled
f>
```

The following is an example of the response one gets by entering the letter “i” to get serial number and other facts of “information” on the X72:

```
r>i
X72 by Symmetricom, Inc., Copyright 2001
      SDCP Version 3.75 of 3/2001; Loader Version 2
      Mode CNN1 Flag 0004
Unit serial code is 0009AB0018-h, current tuning state is 6
Crystal: 3938700hz, ACMOS: 989680.00000000hz, Sine:
989680.00000000hz Ctl Reg: 029C, Res temp off: BFC53F7D,
lamp temp. off: c0074FOE, FC: enabled, Srcv: low
```

The following is an example of entering the letter “h” to get the “help menu” from the X72:

```
r>h
a: Set FC Mode
f: Adjust DDS Frequency (delta e-11)
i: Info (show program info)
j: Display lpps Delta Reg
k: Set lpps TIC
l: Set Service Pin Sense
o: Set ACMOS Output Frequency 'N'
p: Display Control Reg
q: Set Control Reg
t: Dave Tuning Data
w: Display Health Data
x: Exit Run Mode
r>
```

The following print out shows the response to the command for “w” for X72 “*Health Data*” (wellness):

```
r>w
AData:
  SCont: 6012
  SerNum: 18C
  PwrHrs: 18A
  PwrTicks: 11A6848
  LHHrs: 17E
  LHTicks: 83DBD0
  RHHrs: 17E
  RHTicks: 83D2E3
  dMP17: 41883621
  dMP5: 40A158E9
  dHtrVolt: 41381AF5
  PLmp: 3FAA43C6
  PRes: 3FA10F45
  dLVthermC: 39500000
  dRVthermC: B9DD8000
  dLVolt: 3F327288
  dMVoutC: 494005E0
  dTempLo: 00000000
  dTempHi: 42928000
  dVoltLo: 4134DC6A
  dVoltHi: 41C1CA16
  iFpgaCtl: 029E
  dCurTemp: 42690000
  dLVoutC: 3E25B538
  dRVoutC: 3E19A67E
  dmv2 demAvg: 3F337D72
```

The following print out shows how entering the letter “a” followed by an integer sets the “*enable/disable*” feature of FC mode. Integer zero followed by <cr> disables FC mode and any nonzero integer followed by <cr> enables the FC mode.

```
r>a
<nonzero integer-><cr>
FC mode enabled
r>a
0<cr>
FC mode disabled
```

The following print out shows the “*control register*” contents by entering the letter “p”:

```
r>p
Control Reg: 029E
```

Factory Mode

Data output from the X72 in factory mode is not intended for users outside the factory and is not described in this document beyond [Table B-1](#).



Caution: Using factory mode can result in the erasure of firmware on the X72 rendering it inoperable and making it necessary to return the unit to the factory for re-programming.

Floating Point Number Representation

The host PC must convert Floating Point numbers output by the X72 to the host's own floating point using the definition shown in [Table B-1](#). Likewise, the host's floating point numbers must be converted to X72 coding before being sent to the X72.

Table B-1. Floating Point Number Representation for SSIP

Floating Point Format – Single Precision															
31	30	29	28	27	26	25	24	23	22	21	20	19	18	17	16
S	E7	E6	E5	E4	E3	E2	E1	E0	M22	M21	M20	M19	M18	M17	M16
15	14	13	12	11	10	9	8	7	6	5	4	3	2	1	0
M15	M14	M13	M12	M11	M10	M9	M8	M7	M6	M5	M4	M3	M2	M1	M0

Single precision floating point format is a 32-bit format, consisting of a 1-bit sign field, an 8 bit exponent field, and a 23-bit mantissa field. The fields are defined as follows:

Sign <S>: 0 = positive values; 1 = negative value

Exponent <E7-E0>: offset binary format

00 = special cases (i.e. zero)

01 = exponent value + 127 = -126

FE = exponent value + 127 = +127

FF = special cases (not implemented)

Mantissa <M22-M0>: fractional magnitude format with implied 1

1.M22M21 . . . M1M0

Range: -1.9999998 e+127 to -1.0000000 e-126

+1.0000000 e-126 to +1.9999998 e+127

(where e represents 2 to the power of)

The serial interface is initialized as follows:

[Table B-2](#) defines the X72's Run Mode Commands.

[Table B-3](#) defines the bit functions of the factory mode commands of the X72.

[Table B-4](#) defines the administrative mode commands.

[Table B-5](#) defines the bit functions and controlling agent of the output control register of the X72.

Table B-2. Run Mode Commands

User Output to X72		Response to Host	Command Name and Description
Command	DATA		
a	Set FC mode Example: a <zero or non-zero integer> <cr>	To be Specified	Set Analog Frequency Control Mode This command toggles the analog input pin to the unit 'Freq Cntl' between enable and disable. In Factory mode the default is enabled. During factory test the default is set to disable for shipping unless the customer ordered the default to be set enabled.
f	Desired frequency change from free running center frequency in parts to E^{-11} Example: for a $+100xE^{-11}$ change: "100<cr>" Example: for a $-100xE^{-11}$ change: "-100<cr>"	To be Specified	Adjust Frequency Adjust Unit output frequency. Used to discipline the unit. The smallest incremental frequency change is $2xE^{-12}$ (or "f.2"). Any value less than this will still be used. Max value that can be used at one time is $4E^{-8}$. For larger frequency changes, repeated steps equal to or smaller than $4E^{-8}$ should be used. Unit always powers up at free running factory set frequency. This command is always relative to the free running frequency.
h	None	To be Specified	HELP command Displays menu.
i	None	To be Specified	Outputs Unit information While dumping data, clock outputs are not guaranteed to meet specifications during the use of this command.

Table B-2. Run Mode Commands (Continued)

User Output to X72		Response to Host	Command Name and Description
o	N (example of command and data to give 10 MHz for a VCXO of 60 MHz is: "o3")	To be Specified	Loads the value of N to set the ACMOS output frequency N = 1 – 65536. Output FACMOS is equal to crystal frequency divided by 2N. For values outside range, unit sends an illegal notice. E uses the previous valid setting.
p	None	To be Specified	Displays Control Register (See Table B-5).
q	Hex data to set or reset bits in the Control Register immediately follows the command (example "q3A")	To be Specified	Set Control Register Allows enabling or disabling of outputs. See Table B-5 .
t	SAVE command Example: to SAVE changes: "5987717<cr>"	To be Specified	Saves all changes made. NOTE: if the "t" command is not used, unit defaults to factory settings at next power up,
w	None	To be Specified	Displays Health Monitor data

Table B-3. Factory Mode Commands

User Output to X72		Response to Host	Command Name and Description
Command	DATA		
a	None	a>	Goes to Administration mode
i	None	Outputs 6 lines of Banner (same as power-up information)	Displays Unit Information
r	Run Mode	Enter RUN mode. FC mode is disabled (enabled)	Goes to RUN mode



Note: This mode and ADMIN mode allow the loading of new code or updates, or reconfiguring defaults in the field. It is not a normal operating mode.

Table B-4. Administrative Mode Commands

User Output to X72		Response to Host	Command Name and Description
Command	DATA		
a	None	Outputs 6 lines of banner – same as power-up	Unit Information Same as the "i" command in FACTORY mode and RUN mode.
b	"File" from Symmetricom (self-burning)	To be Specified	Operating this command without valid "file" will not overwrite the existing data stored in FLASH memory.
x	None	x f>	EXIT Administrative mode to FACTORY mode
y	None	Y asks "are you sure?"	Soft reset. Restarts processor.
z	None	Z asks "are you sure?"	Puts unit into a mode where it will wake only when the power is recycled.



Note: ADMIN mode allows the loading of new code or updates, or reconfiguring defaults in the field. It is not a normal operating mode.

The output control status register (OSR) bit structure, control features and controlling factors are defined as shown below.

Table B-5. Output Control Status Register Structure

Bit #	Control	Description	Controller
0*	Lamp Switch Power Boost – internal unit function	1 = Lamp Switch is on 0 = Lamp Switch off	Controlled by firmware – Automated Function
1*	BIST Output	0 = Unit is locked 1 = Unit is not locked	Controlled by firmware – Automated Function
2	FXO Enable	0 = Enable FXO output 1 = Disable FXO output	Default is set at Factory per Configuration file that matches customer's selection – Host can alter during operation, but host cannot alter the default power up condition.
3	1PPS Output Enable	0 = Enables 1PPS Output 1 = Disables 1PPS Output	Default is set at Factory per Configuration file that matches customer's selection – Host can alter during operation, but host cannot alter the default power up condition.

Table B-5. Output Control Status Register Structure (Continued)

Bit #	Control	Description	Controller
4	ACMOS Output Enable	0 = Enable Output 1 = Disables Output	Default is set at Factory per Configuration file that matches customer's selection – Host can alter during operation, but host cannot alter the default power up condition.
5*	C-field Boost	0 = Low C-field 1 = High C-field	Controlled by firmware – an automated function.
6	SINE Output Enable	0 = Enables Output to 40% of max output 1 = Disables Output	Default is set at Factory per Configuration file that matches customer's selection – Host can disable SINE output, but host cannot alter the default power up condition. Note: if a SINE filter is not installed, SINE enable will not provide an output.
7*	SINE Output Level Adjust 1	0 = Zero Level 1 = Adds 30% of max Output	Controlled by firmware – set at factory.
8*	SINE Output Level Adjust 2	0 = Zero Level 1 = Adds 20% of max Output	Controlled by firmware – set at factory.
9*	SINE Output Level Adjust 3	0 = Zero Level 1 = Adds 10% of max Output	Controlled by firmware – set at factory.
10*	SERVICE	0 = Unit is OK 1 = Unit requires Service	Controlled by firmware – Automated Function.
11-15	Reserved – Not Used.		

* user cannot set



Note: When altering the Control Register these bits are masked out by firmware, the Host will consider these bits as "DON'T CARE".

Appendix C Using the X72 Developer's Kit

This appendix provides information on using the Symmetricom Serial Interface protocol (SSIP) and includes signal information for connector J1. It also provides a developer interconnect diagram and an interface options diagram.

In This Appendix

- [Introduction](#)
- [Symmetricom Serial Interface Protocol \(SSIP\)](#)
- [Start-up Sequence](#)
- [X72 Development Kit Hardware](#)

Introduction

The X72 Developer's Kit is provided by Symmetricom as a design aid and development tool. It permits a design engineer to experiment with Symmetricom's X72 product in various applications and determine how to implement it in the most advantageous manner.

The developer's kit contains a hardcopy of this document, the X72 unit, a 3 foot (0.914 M) interface cable, the adapter board assembly, application notes, and a CD with electronic files documenting the specifications and performance of the unit. A 90 to 264 Vac universal power supply with an IEC connector is optional and can be specified at time of order.



Note: Users must supply a power cable to connect the adapter board to main power. Users may provide their own +12 Vdc source as long as proper polarity is observed.

Mounting the X72 Unit

The X72 is designed to mount flush onto a heat absorbing surface using the four mounting holes. During demonstration testing if a heat absorbing surface is not available, a suitable heat sink can be ordered as an option.



Note: The mounting screws for the X72 are metric (not SAE) and are 3 mm in size with 0.5 mm thread pitch. They should penetrate no more than 5.0 mm into the X72 base plate.

Interface Cabling/Circuit Cards

The X72 cable is a shielded multi-conductor (26 wires) cable, 3 feet (0.914 M) long with molex connectors at each end. Adapter cards are available in 3.5 inch (8.89 cm) and 1.740 inch (4.42 cm) lengths. A 3.25 inch (8.25 cm) cable is also available.

Connectors

The unit Molex connector is a 52629-2651, 1.00 mm (0.039") pitch, shielded receptacle right angle, SMT connector. The mating connector is a Molex 52660 plug assembly.

Power



Note: The X72 provided in the Developer's Kit operates on 10 to 32 Vdc.

The X72 unit included in the kit is configured at the factory to operate at 10 to 32 Vdc. If the X72 is used without the adapter board a 50 Ω load is required and a 390 pf filter capacitor is recommended to prevent spurs. Additional information on power requirements and precautions can be found in [Electrical Interface](#), on page 36.

Symmetricom Serial Interface Protocol (SSIP)

Setting up and interacting with the X72 unit using SSIP is covered in [Appendix B, Symmetricom Serial Interface Protocol](#).

Turn-on Procedure



Caution: The X72 has no reverse voltage protection and damage will occur if power is applied to the unit in reversed direction.

- Verify that the X72 is mounted to the heat sink supplied or to a customer supplied heat sink device.
- Verify that the power supply is set to the correct voltage (if adjustable) and is unplugged.
- Connect the X72 to a properly terminated, shielded cable that does not have power applied. Once the unit has been properly terminated, plug in the cable to the power supply.

Figure C-1 shows a block diagram of the suggested X72 test setup.

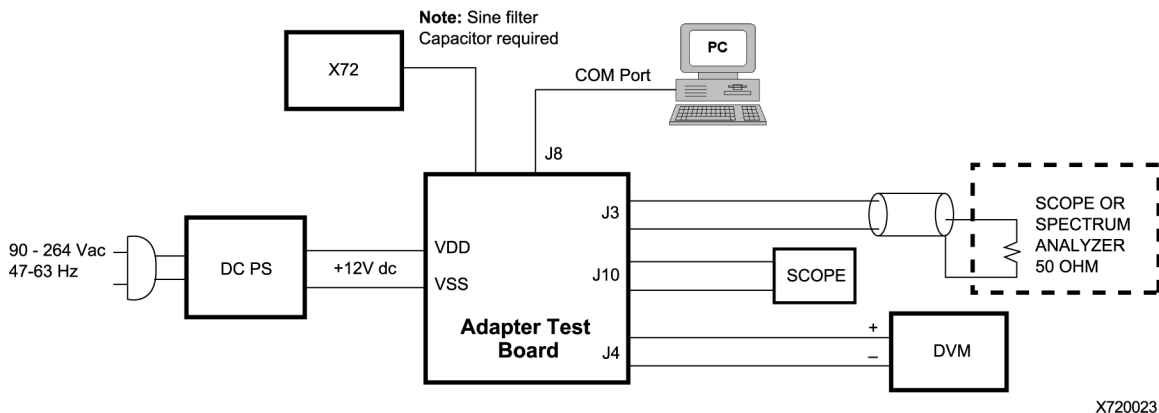

Figure C-1 Suggested X72 Test Setup.

Once The X72 is plugged in and receiving power, wait 3 to 4 minutes while the unit achieves atomic lock. During this period, the monitored LOCK signal should be HIGH. Once the unit achieves atomic lock, the LOCK signal goes LOW.

Depending on base plate temperature, within 4 to 8 minutes the unit should be within 1×10^{-9} of center frequency. Thirty minutes after applying power to the X72 the rf output frequency will be very close to full accuracy (refer to X72 specifications).



Note: The output frequency of the X72 is more accurate than most counters. Appropriate measurement equipment can be obtained from Symmetricom. Inquire with Symmetricom Marketing, or your local sales representative, about Symmetricom's line of test and measurement standards, which includes the PRFS portable rubidium frequency standard and the FMS-2000 frequency measurement system.

Figure C-2 is a top view of the X72 case. Figure C-3 is a diagram of the base plate showing mounting holes. Table C-1 provides signal information for the J1 connector.



X720024

Figure C-2 Top View of X72 Case

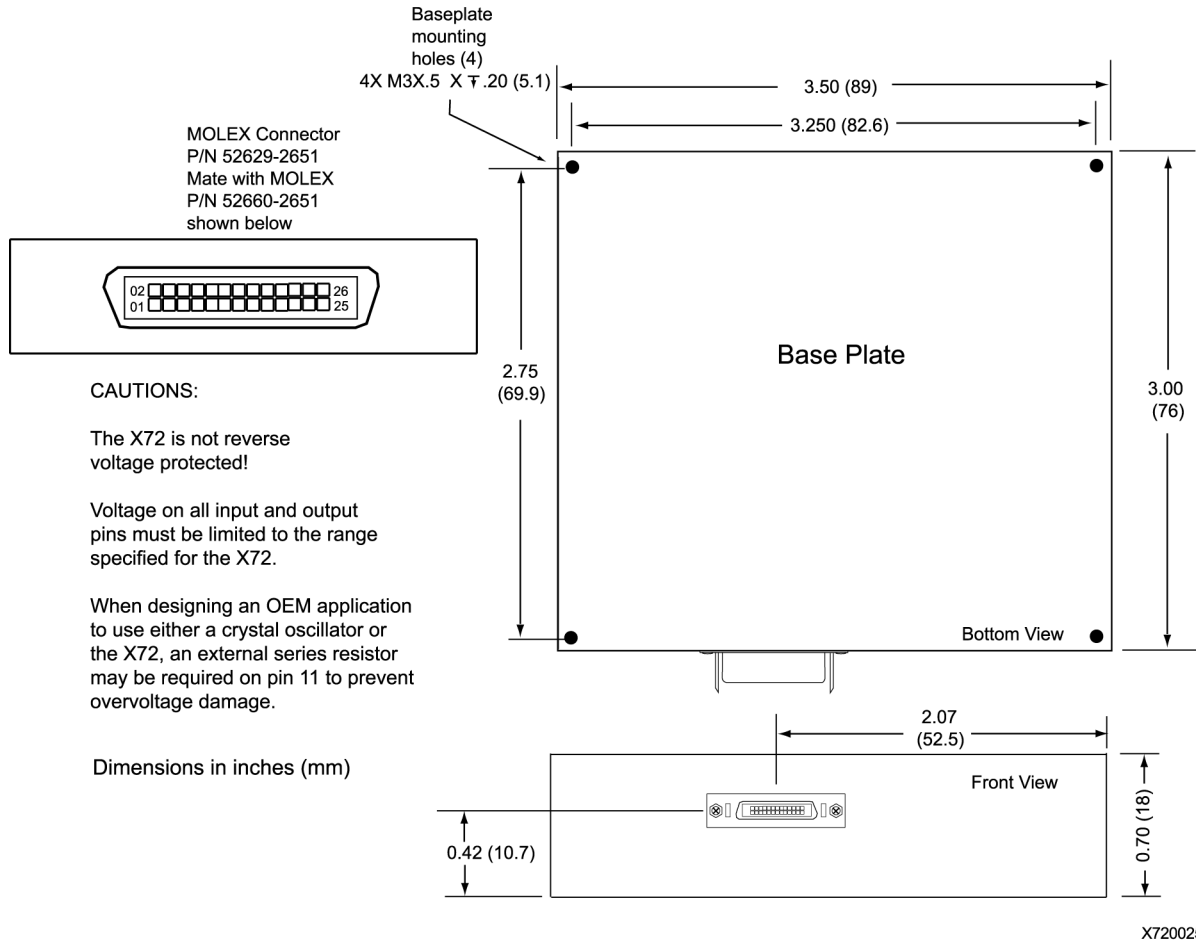

Figure C-3 X72 Dimensions

Table C-1. Connector J1 Signal Information

PIN#	SIGNAL NAME	TYPE ¹	SIGNAL FUNCTION
1 - 7	VDD (bundled)	PWR	+ Power input
8	SERVICE	Output	Service required within 30 days based on unit health
9	DOUT	Output	UART data out AC MOS logic level
10	DIN	Input	UART data in to oscillator
11	FREQ CTRL	Analog	Frequency control – analog input between 0 and 5 Vdc
12 - 18	VSS (bundled)	GND	– Power & signal return
19	1 PPS IN	Input	1 PPS input, positive edge triggered
20	1 PPS OUT	Output	1 PPS output, may be enabled/disabled digitally

Start-up Sequence

Table C-1. Connector J1 Signal Information (Continued)

PIN#	SIGNAL NAME	TYPE ¹	SIGNAL FUNCTION
21	LOCK	Output	If low, indicates Rb osc. is locked
22	FXO	Output ²	(FXO) AC MOS output equalling the VCXO frequency
23	FACMOS RTN	GND	Return for FACMOS & FXO signals
24	FACMOS OUT	Output	(FACMOS) AC MOS Output Option - equals VCXO frequency divided by 2xN (N is selectable).
25	FSINE RTN	GND	Chassis ground – return signal for FSINE signal
26	FSINE OUT	Output	(FSINE) Sine output option – equals VCXO frequency

Note:

1 All inputs and outputs are ESD protected

2 High impedance



Note: Refer to Appendix A for the listed connector manufacturer's specification sheets.

Start-up Sequence

The accuracy at shipment is $< \pm 5 \times 10^{-11}$ typical when power has been connected for the proper amount of time.

After four minutes the rubidium oscillator will reach a locked condition and its output signals will stabilize.



Note: Signals will appear at the outputs immediately after power is applied to the unit, but these output signals will swing up to $\pm 2 \times 10^{-6}$ until after the oscillator has locked.

After 7.5 minutes the accuracy of the X72 oscillator will be at $< 1 \times 10^{-9}$.

Aging and temperature coefficient performance of the X72 unit will vary according to the application profile specified by the customer at time of order. Refer to the X72 product specification for information on application profiles and unit performance.

Performance of the unit can be monitored and certain parameters can be selectively modified through the SSIP firmware included in the unit. Connect the X72 to the COM port of a PC running Windows 95, or later versions. Use a terminal emulation program, such as Procomm Plus by Symantec or Windows HyperTerminal. The X72 communications interface is described in the following section.

X72 Development Kit Hardware

Test Adapter Board and Edge Adapter Cards

The X72 Development Kit is provided for easy lab setup to evaluate the performance and characteristics of the X72 product.

The development kit consists of an interface test board with connectors, a heat sink, a 3.25 inch (8.25 cm) cable, a 3 foot (0.914 M) interface cable and product documentation. An optional power supply can be ordered. The output (or input) of each connector is identified on the board. A photo of the interface board is shown in [Figure C-4](#).



Note: 10 to 32 Vdc is the recommended method of operation.

To use the SSIP firmware of the X72, connect the serial port of the interface test board to a host PC com port (this cable is supplied by the customer). Refer to [Using the Symmetricom Serial Interface Protocol](#), on page 58 for information on SSIP commands and responses.

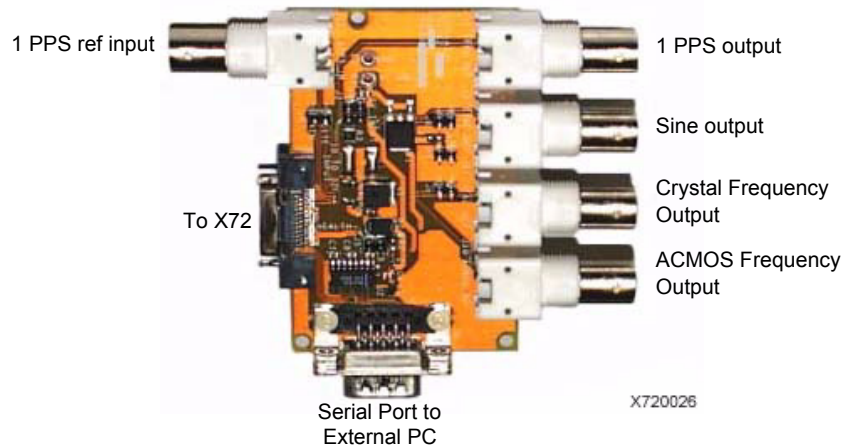
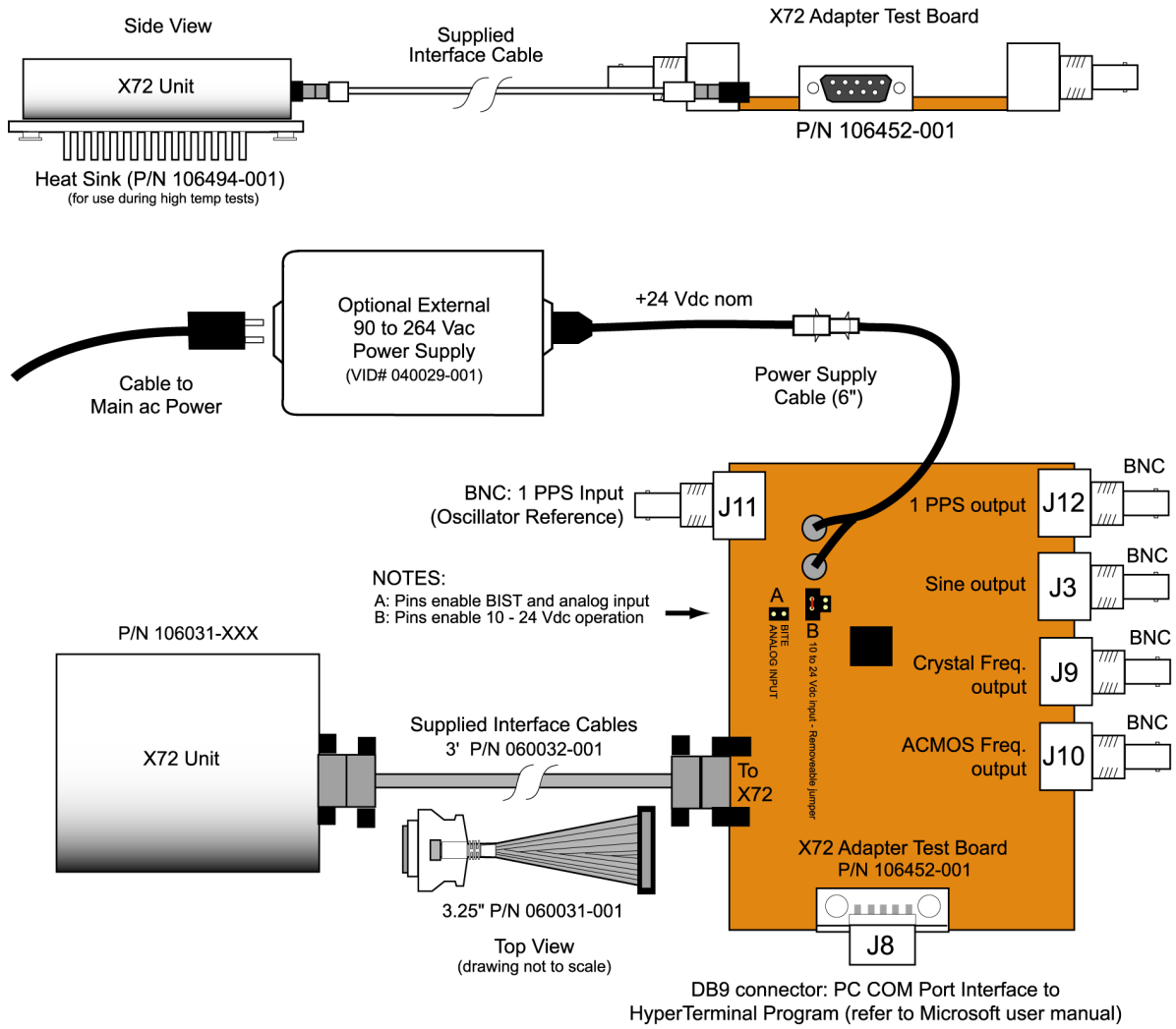

Figure C-4 Top View of X72 Test Interface Board

X72 Development Kit Hardware



X720027

Figure C-5 Developer's Kit (P/N 106495-001) Interconnect Diagram

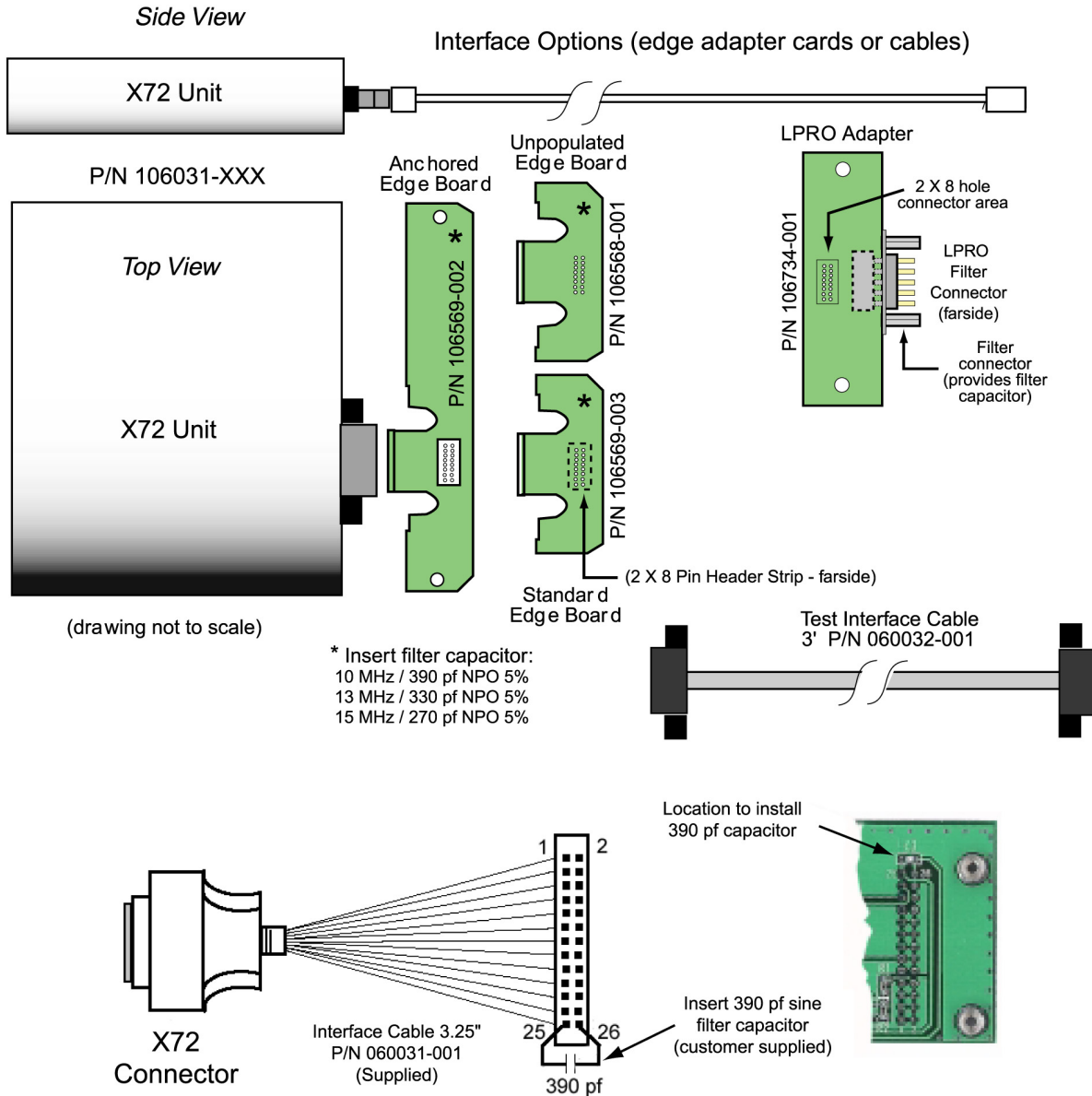

For tests involving measurements of the Spur and Sine Amplitude Output, the Symmetricom supplied 3.25 cable must be used with a customer supplied 390 pf capacitor for optimization of the signal. The capacitor must be connected as shown in the diagram above.

This capacitor is not required for the 3' cable.

X720028

Figure C-6 X72 Interface Options

Appendix D One Pulse Per Second Source Connection

This appendix describes how to connect a one pulse per second (1PPS) source, such as a commercial GPS receiver, to an X72 to achieve long term accuracy and excellent holdover, or flywheeling performance.

In This Appendix

- [Connection Requirements](#)
- [Background](#)
- [X72 1PPS Functions](#)
- [System Requirements](#)
- [X72 1PPS Algorithm Operation](#)
- [Setting the X72 for 1PPS Synchronization](#)
- [1PPS Firmware Versions](#)
- [Flywheeling Recovery – Normal](#)
- [Recovery with JamSynch](#)
- [X72 1PPS Algorithm Theory of Operation](#)

Connection Requirements

The following connections are required for 1PPS setup:

- Power
- GPS antenna
- 1PPS from the source to the X72

No serial port communication is required for initial setup unless you want to make changes from the factory default settings. Information on setup, operation, and integration is provided.

This document applies to X72s manufactured after November 2003 with customer firmware versions 5.02 or higher (see [Table D-2](#) for applicable versions).

Background

GPS technology has made possible time and frequency synchronization world wide. Connecting the 1PPS output from a commercial (civilian) GPS receiver to an X72 provides a cost effective system that maintains highly accurate time and frequency even when GPS signals become unavailable, for example jamming and during antenna maintenance.

The GPS system provides worldwide 1PPS signals with extremely good long term stability (i.e. $< 1 \times E^{-12}$ averaged over 24 hours). However, the short term stability of this signal is often compromised by various noise sources, for example man-made, atmospheric conditions, crosstalk, RF multi-path or inter-symbol interference, and GPS receiver oscillator limitations.

Symmetricon has pioneered the use of rubidium oscillators in telecommunications applications. Telecommunications applications often require long term and short term stability beyond the range of free running quartz oscillators. For example, cellular CDMA systems often require 1PPS signals to be synchronized within 2 μ s over very long periods of time even when GPS signals are not available. To achieve this performance, system designers must combine the benefits of short term stability (from a rubidium or low noise OCXO) with long term stability (from GPS, Loran-C, Glonass, or Cesium). Symmetricon is the leader in system products with microprocessor driven circuitry that uses the GPS 1PPS system to steer various oscillators (Cesium, Rubidium, and Quartz). These products make it possible to combine the short term with long term stability. Now, with X72, the solution can be even more cost effective. When used with a GPS receiver the X72 provides telecommunications system performance levels that rival levels obtained using Cesium oscillators.

X72 1PPS Functions

The X72 can be configured to:

- Generate a rubidium controlled 1PPS signal
- Measure the difference between an incoming 1PPS signal and the X72 1PPS
- Synchronize the X72's frequency and 1PPS output to the incoming 1PPS and provide very long holdover times.

Figure D-1 shows the X72 1PPS disciplining block diagram.

When an externally generated 1PPS signal is applied to pin 19 of J1 (26 pin connector) on a properly configured X72 the unit can provide the time interval error difference between the 1PPS input and the 1PPS generated inside the X72 (see Table D-1). The difference is read using the RS232 communications "j" command. The "j" command displays the difference between the 1PPS input and the 1PPS generated internally by the X72. The "j" command produces a number representing the number of TICS in a delta register. If the X72 has a 60 MHz crystal, each TIC is 16.7 ns (1.67×10^{-8}). Note that this number is in hex format.

A more convenient configuration is to allow the X72 to be disciplined by the incoming 1PPS signal. Figure D-2 shows the test bench setup. The 1PPS disciplining mode is enabled by default. It can be temporarily disabled by issuing the "g" command followed by a "1" (see The "g" Command, on page 83). Typical performance data for this configuration is shown in Figure D-3 and Figure D-4.

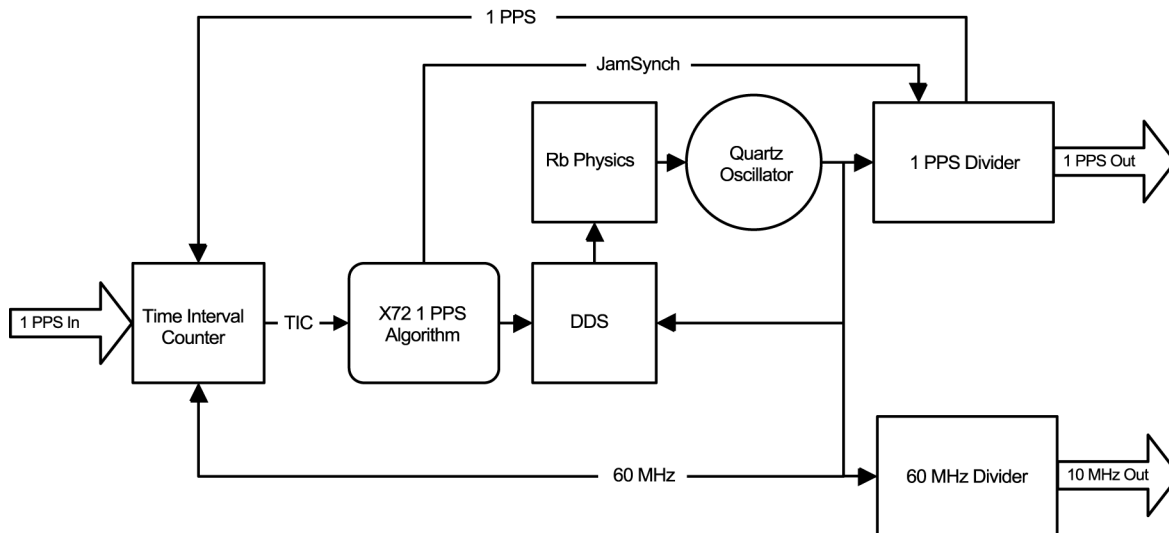

X720029

Figure D-1 X72 Time and Frequency Control System

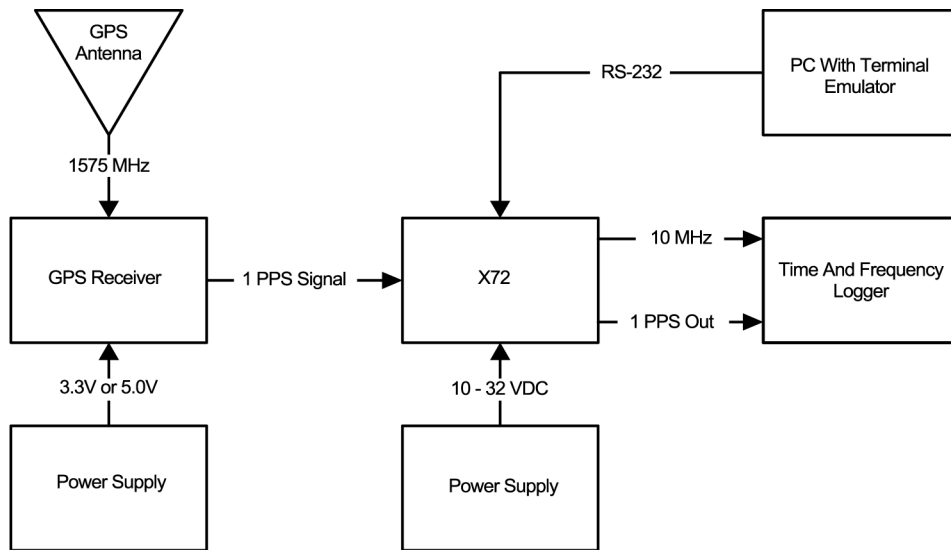

X720030

Figure D-2 Test Bench setup

System Requirements

The following information lists the requirements for 1 PPS setup and operation:

- X72 with 1PPS output enabled.
- GPS receiver with less than 300 ns noise.
- One pulse per second input signals must have repeatable rise time with minimal ringing and must conform to the following:
 - 1PPS input can be driven by a standard 3.3 volt logic, 5 volt CMOS, or 5 volt TTL with normal operation at:
 - Input voltage logic high: 2.00V minimum
 - Input voltage logic high: 5.50V maximum
 - Input voltage logic low: 0.00V minimum
 - Input voltage logic low: 0.80V maximum
 - Maximum DC overshoot must be limited to 5.5V or 10mA, whichever is easiest to achieve.
 - Maximum DC undershoot must be limited to -0.5V or 10mA, whichever is easiest to achieve.
 - Minimum pulse width (or hold time) of 50 ns.

- Input impedance is $>100K \Omega$ allowing the user to terminate the 1PPS at the input to the X72 with 50Ω at the X72 input pin or drive the X72 high impedance directly with a low impedance source such as 50Ω or any AC MOS gate as long as the input voltage level at the X72 pin is met as described above.
- The X72 rubidium oscillator subsystem must be locked to achieve synchronization.
- The X72 must be set up with the proper time constant and damping factor.
- X72 adapter kit (106495-001) is recommended to facilitate setup.
- PC running Microsoft Windows with terminal emulation program. (57600bps, 8 bits with no parity).

X72 1PPS Algorithm Operation

There are two parameters that can be modified by the user for 1PPS synchronization using the “y” command – Damping Factor and Tau.

Damping factor – determines the relative response time and ringing in response to each step. Values should be between 0.25 and 4. Values less than 0.25 will default to 0.25 while values over 4 will default to 4.

Tau (or time constant) – expressed in seconds and determines the time constant of the PLL for following a step in phase for the reference. The range of Tau is 5 to 100,000 seconds. Values outside this range will cause both the Damping Factor and Tau to change to the factory default settings.

Factory Default

The factory default requires no inputs to the rubidium oscillator from the user. The default value for Damping Factor is 1 and the default Tau is 400. These values are a good starting point and will work well for most GPS applications.

Setting the X72 for 1PPS Synchronization

The following assumes the X72 has a 1PPS enabled Customer version of firmware at revision 5.02 or greater installed.

- Connect the X72 to the Adaptor Test Board of the Developer’s Kit or to a correctly configured equivalent system. (See [Appendix C, Using the X72 Developer’s Kit](#))
- Ensure the terminal emulation program is configured to 57,600 BPS, 8 bits, no parity, no flow control and that the keyboard caps lock is off. All input should be lower case.

- Apply power to the system. You will see header information from the X72 displayed similar to the following where you should confirm the firmware version.

```
X 7 2 by Symmetricom, Inc., Copyright 2004
SDCP Version 5.02 of 4/2004; Loader Version 2
Mode CN1B Flag 0005 Unit serial code is 0311BB0198-h,
current tuning state is 6
Crystal: 3938700hz, AC MOS: 989680.00000000hz, Sine:
989680.00000000hz
Ctl Reg: 0204, Res temp off: BFC53F7D., Lamp temp off:
C003B7E9.
FC: disabled, Srvc: low

r>
```



Note: It is not necessary for the X72 to be locked to enter the 1PPS configuration commands, but it must be locked for actual synchronization to occur.

Changing the “y” Coefficients

- At the `r>` prompt, type **y**, then **1**, then **Enter** (1 indicates that you wish to enter the Damping Factor).
- Enter a value between 0.25 and 4 and press **Enter** (see [Note 3](#), on page 84 and [X72 1PPS Algorithm Operation](#), on page 81).
- At the `r>` prompt, type **y**, then **2**, then **Enter** (2 indicates that you wish to enter the Time Constant).
- Enter a value between 5 and 100000 and press **Enter** (see [Note 3](#), on page 84 and [X72 1PPS Algorithm Operation](#), on page 81).
- At the `r>` prompt, type **z**. This saves the 1PPS configuration data to non-volatile memory. If the y coefficients are not saved with the z command, the X72 reverts to the previously saved configuration upon restart. The X72 responds with the following output see [Note 9](#), on page 84):

```
r>z
Saving Tdata 2, serial number xx
1PPS Coefs saved
```

The “y” Coefficients – Factory Default

If the factory default values of Damping Factor = 1 and Tau = 400 are acceptable for your application, no modifications to the y coefficients are required. The X72 1PPS disciplining is enabled at the factory allowing the unit to work right out of the box. If you wish to return the y coefficients to the factory defaults, enter the value 0 for both the Damping Factor and Tau using the process described in [Changing the “y” Coefficients](#), on page 82. This causes the X72 to operate at the factory default Damping Factor of 1 and Tau of 400.

The “j” Command

Press the **j** key at any time to return the current value in hex format from the Delta Register (see [Note 1](#), on page 84) as well as the 1PPS state (see [Note 2](#), on page 84 below and the following table). The output format appears similar to the following:

```
r>j
Delta Reg: 39386F5 lppsState:6
```

Table D-1. 1PPS States Returned with the j Command

Description	Expected Values	Action Being Performed
INITIALIZE0STATE	0	Start up initialization
INITIALIZE1STATE	1	Start up initialization
INITIALIZE2STATE	2	Start up initialization
HOLDOVERSTATE	3	Seeking usable 1PPS
JAMSYNC1STATE	4	Synch X72 output 1PPS to input
JAMSYNC2STATE	5	Synch X72 output 1PPS to input
DISCIPLINESTATE	6	Keep X72 output 1PPS aligned to input by controlling X72 frequency
PIDCALCSTATE	7	Calculations for disciplining algorithm
PDATEDDSSTATE	8	Update X72 DDS based on PIDCALCSTATE output.
ALCSLOPESTATE	9	Calculate slope of incoming 1PPS vs. X72 1PPS during holdover.

See [X72 1PPS Algorithm Theory of Operation](#), on page 87 for additional information on 1PPS states.

The “g” Command

The “g” command allows you to change the X72 to operate in any of three modes which affect the output of the Lock Pin (pin 21). Note that this 1PPS mode can be changed by the user but cannot be saved. If power is cycled to the unit it reverts to the factory default. The modes are:

- 0 = 1PPS Disciplining Disabled – Normal Rb Lock Pin functionality. Only the Rb loop needs to be locked to indicate a locked condition on pin 21.
- 1 = 1PPS Disciplining Enabled – Normal Lock Pin functionality. Only the Rb loop needs to be locked to indicate a locked condition on pin 21.
- 2 = 1PPS Disciplining Enabled – Requires both Rb loop to be locked AND 1PPS synchronization lock to indicate a locked condition on pin 21.

Note that there are two types of 1PPS Customer firmware. The *1PPS Standard* firmware provides an Rb or Rb/1PPS lock indicator at pin 21 and a Service indicator on pin 8 of the X72 I/O connector. The *1PPS LED* firmware uses the same functions for pin 21, but pin 8 is reserved for 1PPS lock indication only. There is no Service pin on the *1PPS LED* versions. The factory default mode set by the g command for each firmware version is:

- 1PPS Standard Firmware – Mode 2. Rb lock and 1PPS lock indicated on pin 21.
- 1PPS LED Firmware – Mode 1. Rb lock only indicated on pin 21 and 1PPS lock indicated on pin 8.

The key sequence to change the output/lock indicator mode with the g command is as follows:

- At the `r>` prompt, type **g** then type either **0**, **1**, or **2** depending on the desired output mode and press **Enter**.



Notes:

1. These numbers are in HEX format.
2. 1ppsStates: 0 to 2 – Initialize; 3, 9 – Holdover; 6 to 8 – Disciplining.
3. When connecting to a GPS receiver, the factory default mode is recommended. Start with y1=1 (DF) and Y2=400 TC in seconds). These values work well for most GPS receivers.
4. Use “z” command to save your settings.
5. X72 Rubidium system locks approx. 5 minutes after startup.
6. X72 initial frequency must be less than ± 3PPB for 1PPS to lock.
7. Initial 1PPS lock occurs between 3 and 5 minutes after both lock and valid 1PPS are present.
8. Confirm the firmware version by issuing the “i” command.
9. xx is a value returned which is the hex equivalent of the number of times the table has been written to. TData can be either 1 or 2.

Table D-2. 1PPS Firmware Versions

Customer Standard	Customer LED
5.06	5.08

Flywheeling Recovery – Normal

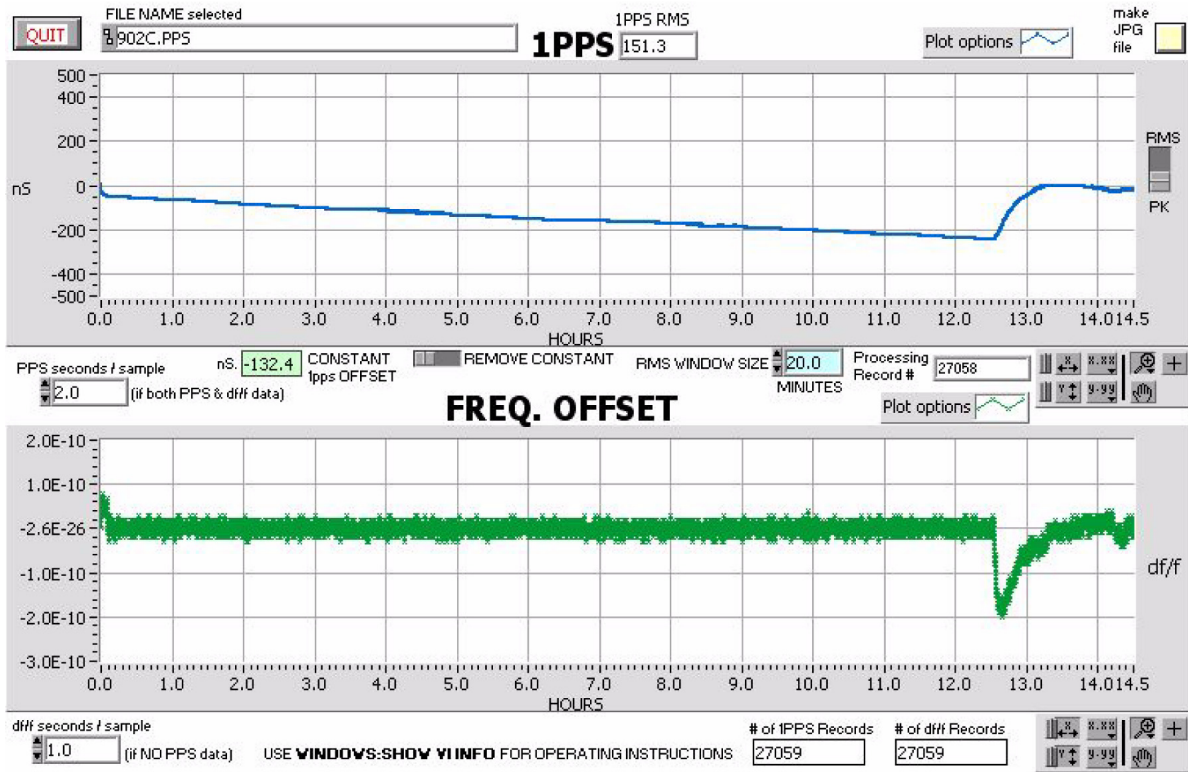

X720031

Figure D-3 Flywheeling Recover with 1PPS offset < 1µsec

In this test the X72 was synchronized to 1PPS before this data set. Antenna is removed at hour 0 and reapplied at approximately hour 12.5. The X72 1PPS output signal had reached an offset of 220 nanoseconds.

The subsequent frequency change is what returns the 1PPS offset to 0 nanoseconds.

Recovery with JamSynch

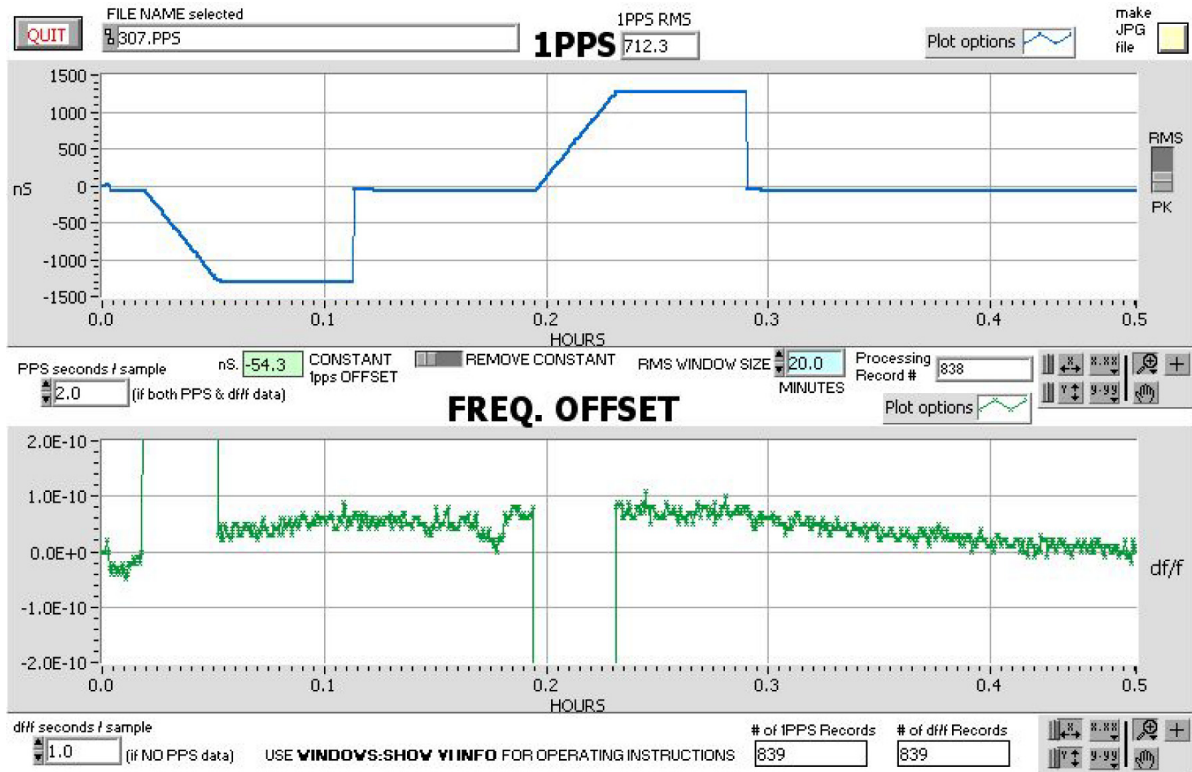

X720032

Figure D-4 Flywheeling Recover with 1PPS offset > 1µsec

In this test, the antenna to the GPS receiver is removed. The X72 is purposely put off frequency long enough to induce a 1PPS error over 1µsec. When the antenna is reapplied, the X72 1PPS recovers by resetting to 1PPS 0 nanoseconds (JamSynch). This procedure was repeated to cause both a leading and lagging 1PPS.



Note: This test was performed on a unit started “cold” which is what causes the general curve in the frequency data (excluding the intentional offsets).

X72 1PPS Algorithm Theory of Operation

X72 qualifies 1 pulse per second inputs by analyzing the time difference between the X72's 1PPS output and the external 1PPS input. This is referred to as the HoldOver state. The X72 determines whether the 1PPS input is useable by calculating the rate of change in timing measurements that are taken once per second.

Once a 1PPS input is qualified, the X72 1PPS algorithm determines if it is necessary to adjust the counter that produces the 1PPS output (JamSynch state). The algorithm then begins to adjust the output frequency of the X72 to keep the 1PPS output aligned with the 1PPS input. This is the disciplining state and the control method is a Proportional Integral Derivatives (PID) scheme.

The amount of frequency change and the length of time required to reach 1PPS accuracy can be adjusted by setting y1 (damping factor) and y2 (time constant) parameters. During this disciplining state, the timing of each 1PPS input is compared to the expected value. If the offset exceeds 333 nanoseconds, the algorithm changes to the HoldOver state and the process begins again. Refer to the following figures for additional details.

X72 1PPS Algorithm High Level Flow Chart

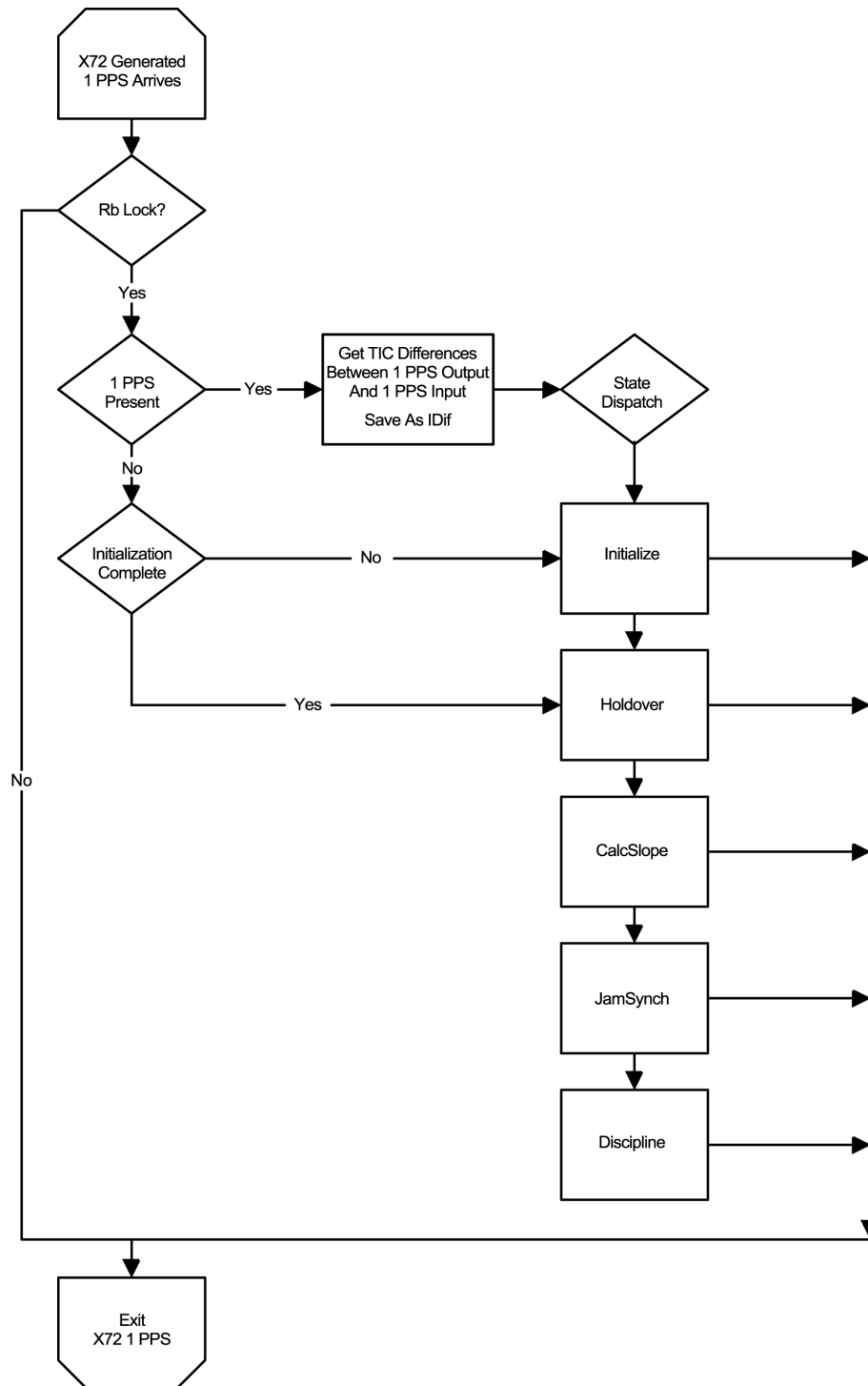

X720033

Figure D-5 X72 1PPS Algorithm States

Initialization

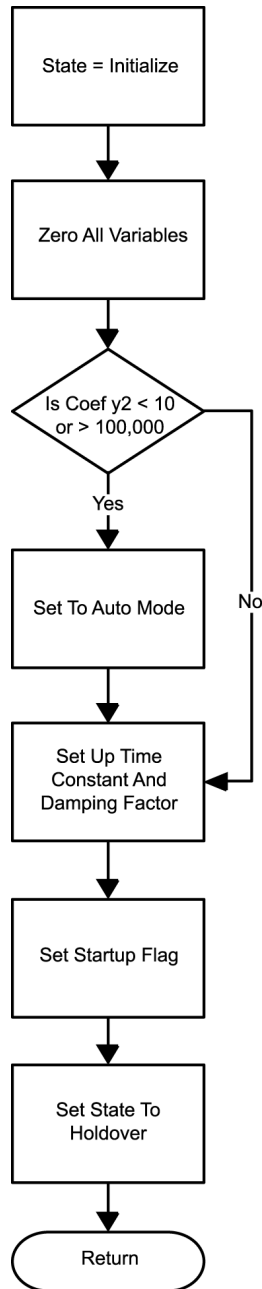

X720034

Figure D-6 X72 Initialize State

During initialization the algorithm sets up variables based on the time constant (TC) and damping factor (DF).

The X72 checks for 1PPS input once per second, and if present, it enters the holdover state.

Automatic mode is used when the time constant is set to 0.

The X72 1PPS is in the initialization state when there is no 1PPS applied.

The “j” command shows the 1PPS count.

Holdover

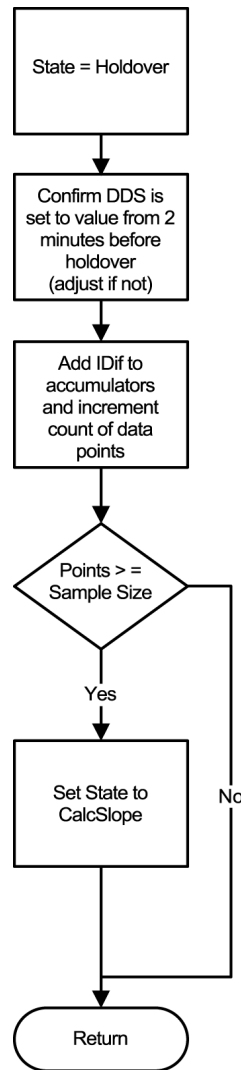

During holdover, 1PPS input statistics are accumulated and periodically the results are calculated (CalcSlope State).

The sample size is set to 120 data points (120 seconds).

X720035

Figure D-7 X72 Holdover State

Calcslope

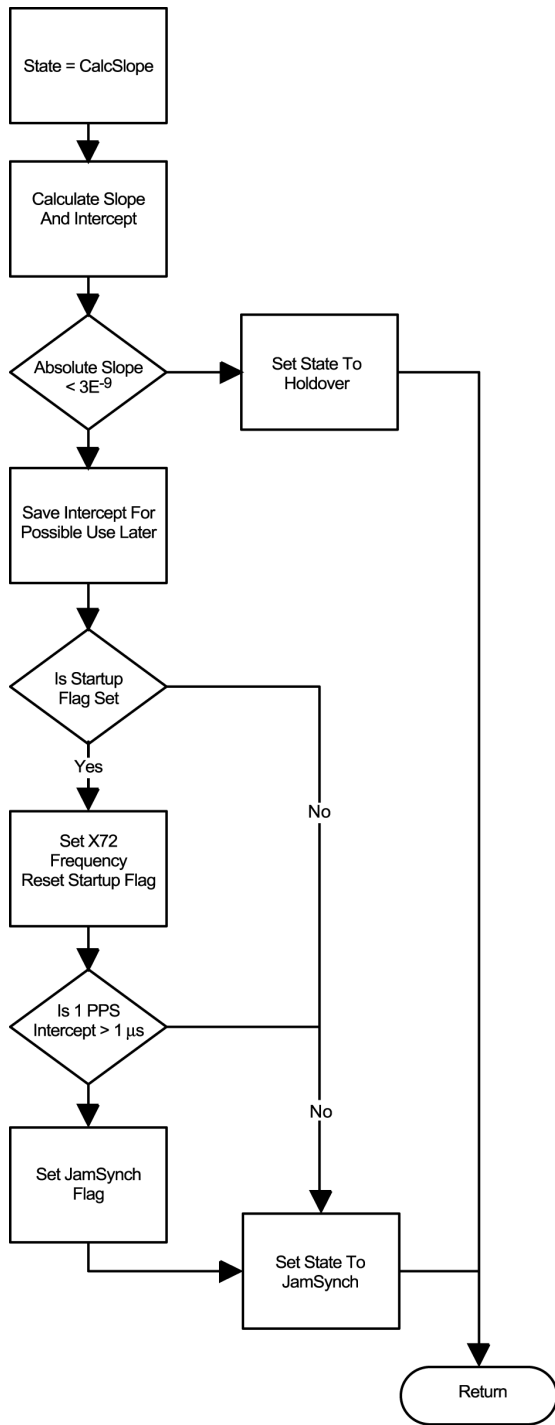

X720036

Figure D-8 X72 Calcslope State

When the frequency difference between the X72 and the 1PPS source is calculated, if the difference is $< \pm 3 \times E^{-9}$ the state changes from holdover to JamSynch.

This state executes every 120 seconds during holdover.

JamSynch

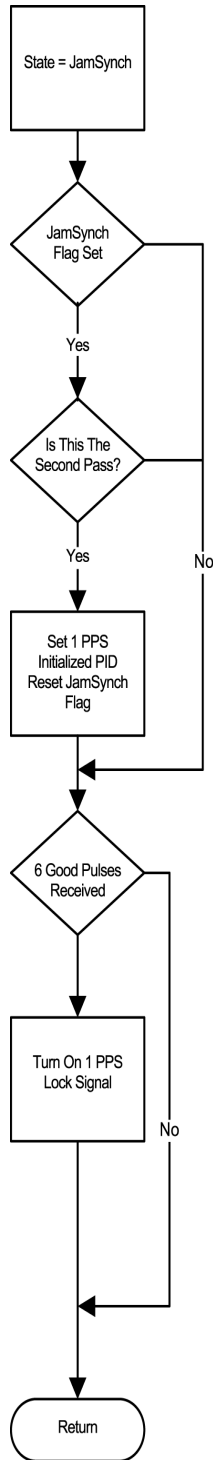

X720037

Figure D-9 X72 JamSynch State

When the X72 1PPS output is compared to the X72 1PPS Input, if the difference is $\geq 1 \mu\text{sec}$. the state returns to holdover to collect a second data set

When two consecutive slopes are in range, the X72's 1PPS output is synchronized to its 1PPS input.

If the difference is $< 1 \mu\text{sec}$. the algorithm waits 6 more pulses and then advances to the Discipline state

Discipline

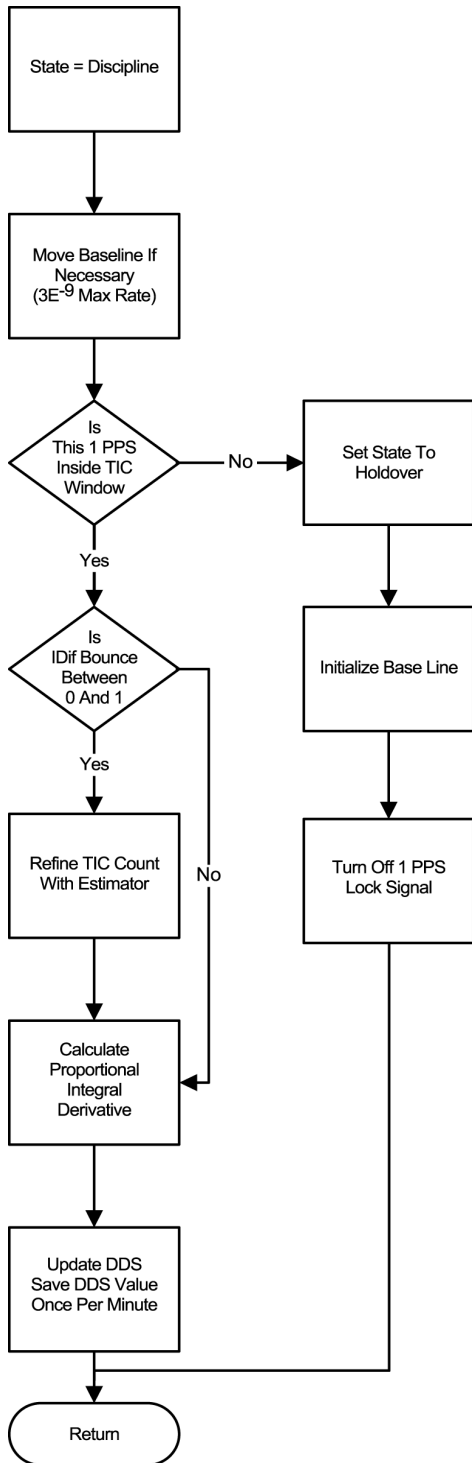

X720038

Figure D-10 X72 Discipline State

In the Discipline State, the X72 uses a PID (proportional-integral-derivative) method to steer the 1PPS output of the X72. This method means the X72 average frequency offset is close to zero. You can expect to see some frequency change when recovering from holdover.

If at any time a 1PPS input signal is more than 330 nanoseconds from its expected value the 1PPS algorithm returns to holdover state.

If the input source is very stable, the X72 further refines the input estimate to provide a smoother frequency output.

Every minute the X72 saves the DDS setting in case holdover occurs. Since some receivers take a long time to produce 330 nanoseconds of error after signal loss, the X72 reverts to the DDS value from 2 periods before the 1PPS becomes invalid.

Index

A

a command [60](#)
accuracy of signal [45](#)
ACMOS output frequency [37](#)
adapter, LPRO [33](#)
administrative mode commands [62](#)

B

bandpass [36](#)
base plate temperature [34](#)
baud rate [58](#)
Built-in Self Test (BIST) [20](#)

C

cable [68](#)
 3.25 inch [32](#), [68](#)
 customer supplied [73](#)
 interface [73](#)
 shielded [28](#)
capacitor [29](#)
 15 μ F [30](#), [31](#)
 390 pF [30](#), [31](#), [36](#)
 coupling [36](#)
 filter [33](#), [69](#)
cautions defined [14](#)
CDMA [19](#)
cellular [19](#)
comm port [58](#)
command control status dialog [20](#)
commands [58](#)
 a [60](#)
 administrative mode [62](#)
 factory mode [62](#)
 h [59](#)
 help [59](#)
 i [59](#)
 p [60](#)
 run mode [58](#), [62](#)
 w [60](#)
communication parameters
 baud rate [58](#)
 data rate [58](#)
connectors [68](#)
 mating [28](#)
contamination [35](#)
control register [65](#)

coupling capacitor [36](#)

D

data rate [58](#)
digital network timing [19](#)
documentation, related [15](#)

E

edge board [29](#)
 anchored [31](#)
 standard [30](#)
 unpopulated [29](#)
embedded controller [20](#)
ESD [35](#)
external timing reference [19](#)

F

factory mode [61](#)
factory mode commands [62](#)
FC mode [60](#)
filter capacitor [33](#)
filtering
 optimum [40](#)
firmware [20](#), [45](#), [48](#), [73](#)
firmware upgrades [48](#)
FLL [47](#)
floating point format [61](#)
frequency control [38](#)
frequency control signal [37](#)
frequency output [40](#)
frequency-locked loop [47](#)

G

GPS [19](#)

H

h command [59](#)
heat sink [34](#), [69](#), [73](#)
heater circuits [20](#)
help command [59](#)

I

i command [59](#)
interface cable [73](#)

interface test board [73](#)

L

LOCK alarm signal [20](#)
 LOCK signal [36](#), [45](#), [69](#)
 LPRO adapter [33](#)

M

magnetic fields [44](#)
 mating connectors [28](#)
 mode
 administrative commands [62](#)
 factory commands [62](#)
 FC [60](#)
 run commands [58](#), [62](#)
 modulation spurs [40](#)
 mounting recommendations [28](#)
 mounting screws [68](#)

N

noise [40](#)
 notes defined [14](#)

O

operating temperature [19](#)
 operating voltage [40](#)
 output control register [62](#)
 output frequency [40](#)
 ACMOS [37](#)
 output signals [45](#)

P

p command [60](#)
 PCS [19](#)
 phase noise [40](#)
 power [68](#)
 power requirement [19](#)
 power source and current pulses [44](#)
 power supply [69](#)
 power up [44](#)
 PRFS [45](#)
 purpose of this guide [12](#)

R

recommendations defined [14](#)
 related documentation [15](#)

resistor, 10 ohm [30](#), [31](#)
 resonance points [40](#)
 rf load [36](#)
 rf output [36](#)
 RMA number [48](#)
 RS232 [19](#)
 run mode commands [58](#), [62](#)

S

screws, mounting [68](#)
 SDH [19](#)
 serial port [20](#)
 service information [41](#)
 service signal [37](#)
 shielded cable [28](#)
 signal
 LOCK [36](#), [45](#), [69](#)
 lock alarm [20](#)
 signal accuracy [45](#)
 SONET [19](#)
 spur integrity [40](#)
 SSIP [20](#), [37](#), [45](#), [58](#), [69](#)
 frequency control [38](#)
 modifying operation [39](#)
 performance monitoring [73](#)
 structure of this guide [12](#)
 Symmetricom Serial Interface Protocol
 (see SSIP)

T

temperature
 base plate [34](#)
 correction [38](#)
 limits [44](#)
 range [18](#), [19](#)
 test board, interface [73](#)
 thermal tape [34](#)
 troubleshooting [48](#)
 typical applications [19](#)

U

upgrades
 firmware [48](#)

V

voltage-controlled crystal oscillator, VCXO
[36](#), [37](#), [47](#)

W

w command [60](#)
warm-up cycle [45](#)

warnings defined [14](#)
warranty [19](#), [48](#)
web address [15](#)
wireless [19](#)

W—W